

IRC:103-2012

**GUIDELINES  
FOR  
PEDESTRIAN FACILITIES**  
*(First Revision)*

*Published By :*

**INDIAN ROADS CONGRESS**

Kama Koti Marg  
Sector-6, R.K. Puram  
New Delhi-110 022

**MAY, 2012**

Price ₹.600/-  
(Packing and postage charges extra)

## GUIDELINES FOR PEDESTRIAN FACILITIES

### 1 GLOSSARY

**Footpath (Footpaths)-** It is a portion of right of way of road used for the movement of pedestrian traffic.

**Street Crossings-** It is a place where streets cross each other and includes all kind of movements of pedestrian & vehicular traffic.

**School Zone Improvements-** Covers engineering issues, facilities, operations, and signage as applied specifically to areas near schools.

**Pedestrian Level of Service (LOS)-** Pedestrian level of service indicates the environmental qualities of a pedestrian space and serves as a guide for development of standards for pedestrian facilities. Environmental factors that contribute to the walking experience and therefore to the perceived level of service, such as comfort, convenience, safety, security and attractiveness, should also be considered.

### 2 INTRODUCTION

**2.1** The Guidelines for Pedestrian Facilities was first published in February, 1989. The work of revision of this document was taken up by the Urban Roads, Streets & Transport Committee (H-8) of the Indian Road Congress. A sub group consisting Prof. P.K. Sarkar as Chairman and Ms. Anjali Agarwal, Dr. (Mrs.) Purnima Parida and Prof. Rajat Rastogi as member was formed to revise the Guidelines. The Sub-group was benefitted with detailed inputs given by Samarthyam, National Centre for Accessibel Environments with all line drawings and illustrations. The revised document as prepared by the Sub-group was considered and approved by the Urban Roads, Streets & Transport Committee (personnel given below) in its meeting held on 8<sup>th</sup> September, 2011:

Sinha, Late V.K.	Convenor (till 21.12.2010)
Kurian, Jose	Co-Convenor, Convenor (w.e.f. 3.03.2011)
Joshi, Dr. G.J.	Member-Secretary

#### *Members*

Ahmad, M. Imtiyaz	Raina, Ramesh
Arasan, Dr. V.T.	Rastogi, Dr. Rajat
Bagish, Dr. B.P.	Rao, Prof. K.V. Krishna
Das, A.K.	Sagar, Sanjay
Gangopadhyay, Dr. S.	Sarkar, Dr. P.K.

Goel, A.K.	Shankar, Dr. Ravi
Jaigopal, R.K.	Sharma, H.K.
Jaiprasad, R.	Singh, Nirmaljit
Johri, H.K.	Sinha, S.
Kandasamy, C.	Srinath, K.
Katti, Dr. B.K.	Verma, Sushil
Murthy, P.R.K.	Director (UTTIPEC)

***Corresponding Members***

Aggarwal, Ms. Anjali	Parida, Dr. (Mrs.) Purnima
Maitri, Dr. Vinay	Sewaram

***Ex-Officio Members***

President, IRC	(Yadav, Dr. V.K.)
DG (RD) & Sp. Secy., MORTH/ Secretary General, IRC	(Indoria, R.P.)

**2.2** The draft was approved by the Highways Specifications and Standards Committee (HSS) in its meeting held on 23<sup>rd</sup> September, 2011 for placing before the IRC Council. The draft was finally approved by the IRC Council in its meeting held on 3<sup>rd</sup> November, 2011 at Lucknow.

**2.3** Walking is an important mode of transport. In urban areas; a significant proportion of trips upto 1-2 km in length is performed on foot. Moreover, every journey necessarily starts and ends as a walk trip. Pedestrian do not consume fuel, fitness is a bonus. Above all pedestrian facilities ensure social equity. It may be added that pedestrian facilities enhance the liveliness of the urban environment, making both business districts and residential neighborhoods safe and interesting. Developing a pedestrian environment means more than laying down a footpath or installing a signal. A truly viable pedestrian system takes into account both the big picture and the smallest details - from how a city is formed and built to what materials are under our feet.

**2.4** Accessible design is the foundation and primary concern for all pedestrian design, hence all pedestrian facilities need to be planned, designed, operated and maintained so that it is usable by everyone, including those with disabilities or using mobility aids. As considerable number of pedestrian traffic is the victims of road accidents, it is therefore important to address various issues of pedestrian while providing facilities for them. Care has to be taken to provide the facilities to pedestrian not only along the roads and intersections, but also at the areas like work places, access to transit areas, markets, schools, etc.

**2.5 Definition of Pedestrian**

"Pedestrian" is used throughout these guidelines to include people who walk, sit, stand in public spaces, or use a mobility aid like walking stick, crutches or wheelchair, be they children,

teenagers, adults, elderly persons, persons with disabilities, workers, residents, shoppers or people-watchers. Pedestrian-oriented design is accessible design for all people.

### 3 SCOPE

**3.1** Every traveller is a pedestrian at some stage of his or her travel and hence pedestrian facilities are very significant in urban transportation. In view of the paradigm shift from 'moving the vehicles' to 'moving the persons' while planning for transportation facilities in cities, provision of integrated and barrier free pedestrian facilities is essential to ensure inclusive mobility.

**3.2** These guidelines cover engineering design and planning aspects of pedestrian facilities on road sides and at road crossings in urban and semi urban areas. Pedestrian facilities at special locations like schools, parking, and transit areas are also covered. Issues related to pedestrian safety audit are highlighted with respect to road safety audit.

**3.3** The guidelines are intended for use by the local authorities responsible for creating and maintaining semi urban and urban road transport facilities. The guidelines are framed to serve the objectives of universal accessibility and social equity for sustainable transportation.

### 4 GENERAL PRINCIPLES

**4.1** Pedestrian facilities should be planned in an integrated manner so as to ensure a continuous pedestrian flow. It should be useful therefore to look at pedestrian needs for an area as a whole and prepare an overall strategic plan.

**4.2** The basic aim should be to reduce pedestrian conflicts with vehicular traffic to the minimum. Efforts should be made to create such conditions that pedestrian are not forced to walk in unsafe circumstances, and that the motorists respect the position of pedestrian.

**4.3** While planning, the convenience of pedestrian should be a paramount consideration to ensure full utilization of the facilities.

**4.4** Pedestrian facilities are a critical element in producing a pedestrian-friendly environment. A number of engineering solutions to improve the quality of the pedestrian network should take into account the following groups: children, families with young children, elderly persons, persons with disabilities, and people carrying heavy luggage.

**4.5** The mobility and safety of "all" the pedestrian, including those with disabilities and reduced mobility should be ensured to promote inclusive mobility and universal accessibility.

**4.6** Above all, regular maintenance of all facilities and design elements should be undertaken to maintain accessibility, reliability, usability, safety and continuity.

**4.7** While planning and design the pedestrian facilities, the overall objectives would be continuity, comfort and safety

### 5 PEDESTRIAN LEVEL OF SERVICE

#### 5.1 Quality of Service

Pedestrian spaces should be designed in consideration of human convenience and have to be qualitatively suitable to the needs of human beings. Nine parameters affect the quality of

service of a footpath facility out of which six are pertaining to the physical characteristics of the footpath facility, like footpath width, footpath surface, obstruction, encroachment, potential of vehicular conflict, and continuity. The three user factors are pedestrian volume, security, comfort and walking environment.

## 5.2 Concept of Pedestrian Level of Service

Pedestrian level of service indicates the environmental qualities of a pedestrian space and serves as a guide for development of standards for pedestrian facilities. Pedestrian spaces should be designed in consideration of human convenience and have to be qualitatively suitable to the needs of human beings. The planning and design methods for pedestrian suggested by many researchers are based primarily on vehicular traffic flow theory. Additional environmental factors that contribute to the walking experience and therefore to the perceived level of service, such as comfort, convenience, safety, security and attractiveness, should also be considered. Within the pedestrian LOS definition, six levels of service can be expressed as under:

- (i) LOS A is a pedestrian environment where ideal pedestrian conditions exist and the factors that negatively affect pedestrian LOS are minimal.
- (ii) LOS B indicates that reasonable pedestrian conditions exist but a small number of factors impact on pedestrian safety and comfort. As LOS A is the ideal, LOS B is an acceptable standard.
- (iii) LOS C indicates that basic pedestrian conditions exist but a significant number of factors impact on pedestrian safety and comfort.
- (iv) LOS D indicates that poor pedestrian conditions exist and the factors that negatively affect pedestrian LOS are wide-ranging or individually severe. Pedestrian comfort is minimal and safety concerns within the pedestrian environment are evident.
- (v) LOS E indicates that the pedestrian environment is unsuitable. This situation occurs when all or almost all of the factors affecting pedestrian LOS are below acceptable standards.
- (vi) At LOS F, all walking speeds are severely restricted, and forward progress is made only by shuffling. There is frequent, unavoidable contact with other pedestrian. Cross and reverse-flow movements are virtually impossible. Flow is sporadic and unstable. Space is more characteristic of queued pedestrian than of moving pedestrian streams.

Illustrations for quantitative Pedestrian Level of Service for sidewalks and Pedestrian L.O.S. thresholds for cross walks are given in **Annexure-I**. The relationships between pedestrian flow characteristics of speed, flow and density are also illustrated in the **Annexure**.

## 5.3 Physical Characteristics

The pedestrian facilities shall comply with following physical characteristics:

- (i) **Footpath Surface:** an even surface without cracks or bumps for comfortable walking. All surfaces should be stable, firm, and slip resistant.

- (ii) **Footpath Width:** The footpath should be wide enough to accommodate pedestrian flow at any given point of time.
- (iii) **Obstructions:** The obstruction can be an electric pole, tree, garbage bin, and hoardings. The location of garbage bin, electric pole and any other feature like signage etc. should be on one side of the footpath so as to give a clear walkway to the pedestrian.
- (iv) **Encroachment:** The informal commercial activities are an integral part of the footpath environment in India. The pedestrian also need them as they cater to their day-to-day needs, but sometimes the extent of encroachment rises to a level that the footpath facility becomes inaccessible/ non-usable by the pedestrian. The informal sector has to be integrated in the overall design of the footpath facility by providing space for them to operate.
- (v) **Potential for Vehicle Conflict:** The footpaths need to be segregated from the roads, where fast moving vehicles ply. The two ways to protect the pedestrian from vehicle conflicts is the raised footpaths and the guardrails.
- (vi) **Continuity:** The continuity of the pedestrian facility is very important for the pedestrian with disability and of old age. Frequent kerb cuts along a street both impede traffic flow and create more conflict points between vehicles and pedestrian, thus reducing the effectiveness of footpaths. Frequent ups and downs make the footpath uncomfortable to use by the pedestrian especially the old and forces the pedestrian to share the carriageway along with the vehicles. The provision of kerb ramps is essential for continuity of the footpath.

#### 5.4 User Characteristics

Following user characteristics shall be given the consideration while planning/designing pedestrian facilities:

- (i) **Safety & Security:** The feeling of being secure is the most important governing factor. A pedestrian should feel safe during the day as well as night while using a footpath/crosswalk. Characteristics of this factor include provision of adequate street lighting, police patrolling during the night time and sufficient activities on the surrounding areas to ensure safety. Separation of pedestrian traffic and vehicular traffic with the provision of pedestrian's footpaths ensures safety of pedestrian and ensures less chance of pedestrian from entering the carriageway even unintentionally. It is therefore, strongly recommended that pedestrian footpaths be provided on all new facilities, and on all existing facilities as far as practicable (IRC:70-1977 "Guidelines on Regulation and Control of Mixed Traffic in Urban Areas" may be referred for this).
- (ii) **Comfort:** A pedestrian needs to be protected from the inclement weather like harsh sun and rain. The trees protect the pedestrian but if planted in an unplanned manner also act as an obstruction. The location of trees

and the plants need to be carefully planned. Provision of chairs /benches, rain shelters and wash rooms is another factor that adds to the comfort of pedestrian.

- (iii) **Walk Environment:** Walk environment is governed by the surroundings of the facility. The walking should be a pleasant experience. The footpath should be clean and free of stink.

## 6 PEDESTRIAN FACILITIES DESIGN STANDARDS

### 6.1 Footpath

**6.1.1** Pedestrian footpaths are defined as any area primarily used by 'all' pedestrian. They can be adjacent to roadways, or away from the road.

**6.1.2** Footpaths should be regarded as a transportation system which is connected and continuous, just like roadways and railways. They should not be sporadically placed where ever convenient, but instead should be provided consistently between all major attractions, trip generators, and other locations where people walk. In order to be effective, the side-walks should be provided on both sides of the road and above the level of the carriageway separated by kerbs. Height of the kerb at the edge should, however, not exceed the height of a standard public step riser i.e. 150 mm.

#### 6.1.3 *Clear walking zone*

In the natural and tempered landscapes, paths should be at least 1800 mm wide in order to accommodate wheelchair users and persons with vision impairments assisted by a sighted person or guide dog. It will also allow, for instance, an adult and child to walk together. If existing paths are less than 1800 mm wide, provision of passing places, 1800 mm wide and 2500 mm long, shall be made at a reasonable frequency, depending on intensity of use. This will allow groups of persons to pass each other, particularly on busy routes. Where the effective width is constricted by, for example, existing trees or walls, paths may reduce to 1200 mm for short distances. A 1200 mm wide path is too narrow for persons to pass each other, hence provision of passing places should be made at a greater frequency. A change in surface at the edge, such as a grass or ground or a verge, which often occurs naturally anyway, will help to prevent persons from straying off the path.

The minimum 1.8 m (width) x 2.2 m (Height) Walking Zone should be clear of all obstructions – both horizontally and vertically. No utility ducts, utility poles, electric, water or telecom boxes, trees, signage or any kind of obstruction should be placed within the "Walking Zone" (Fig. 1).

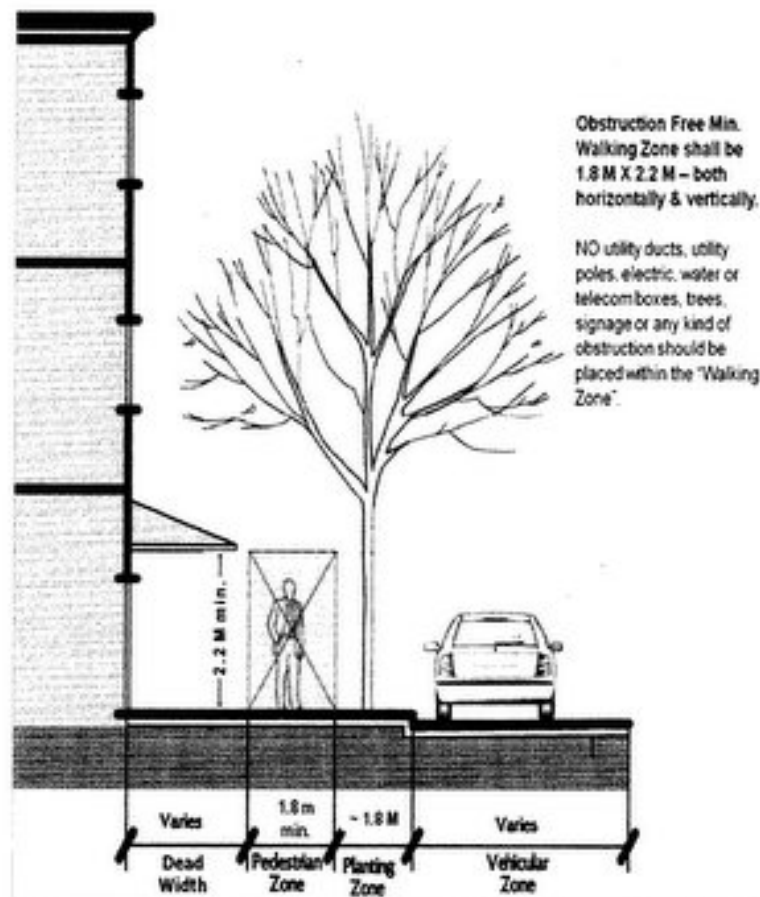

Fig. 1 Clear Walking Zone is separate from Planting Zone

#### 6.1.4 Clear height

A clear height of 2.2 m is required for the entire width of the footpath walking zone. No tree branches, trees, utility poles, electric/water/telecom boxes or signage should be placed within the clear height and width of the Walking Zone.

#### 6.1.5 Width

6.1.5.1 The width of a footpath is fundamental to the effective functioning of the pedestrian system. Without an optimum width, footpath will not help move enough pedestrian and will discourage them from walking. The width of side-walks depends upon the expected pedestrian flows and could be fixed with the help of guidelines given in **Table 1**. The minimum width of a clear unobstructed pathway should be 1800 mm in roads of right of way of 10 m and above. This allows two wheelchairs to pass each other comfortably (**Fig. 2**). In case of road with right of way less than 10 m or in the areas with light pedestrian traffic, a width of 1500 mm is regarded as the minimum acceptable, giving enough space for a wheelchair user and a walker to pass each other. As an exception, the width of the footpath may be considered as 1500 mm. The full width of footpath should be maintained consistently, even behind bus shelters and in front of shop. For the actual length or width of people and equipment, the clearance lengths



and clear outdoor passage widths needed for those people and equipment, **Annexure-I** can be referred to.

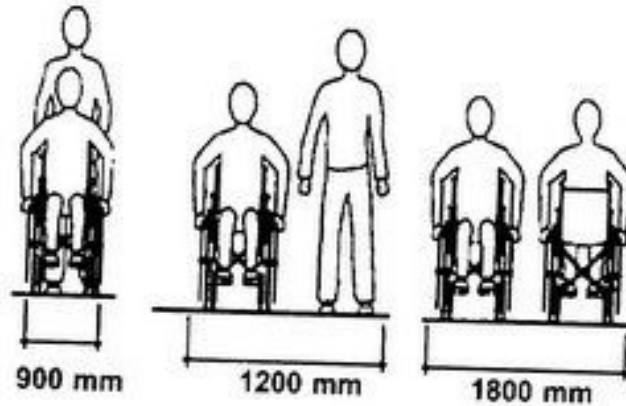

Fig. 2 Minimum Width of a Clear Footpath

6.1.5.2 Footpaths should normally be designed for a pedestrian Level of service B, thereby providing wide pedestrian facilities for pleasant and comfortable walking. Under resource constraint, Level of Service C can be adopted for deciding width of footpath (**Table 1**). The width of the footpaths depends upon the expected pedestrian traffic and may be fixed with the help of the following guidelines subject to not being less than 1.8 m (**Table 1**).

Table 1 Capacity of Footpath

Width of side-walk (meter)	Design Flow in Number of Persons per hour			
	In Both directions		All in One direction	
	LOS B	LOS C	LOS B	LOS C
1.8	1350	1890	2025	2835
2	1800	2520	2700	3780
2.5	2250	3150	3375	4725
3	2700	3780	4050	5670
3.5	3150	4410	4725	6615
4	3600	5040	5400	7560

The land use adjacent to roads significantly influences generation of pedestrian traffic. Recommended width of footpath along various landuses are given in **Table 2**.

Table 2 Required Width of Footpath as per Adjacent Landuse

Minimum obstacle free walkway width and Residential/ Mixed Use Areas	1.8 m
Commercial/ Mixed Use Areas	2.50 m
Shopping frontages	3.5 m to 4.5 m
Bus Stops	3 m
High Intensity Commercial Areas	4 m

### 6.1.5.3 *Frontage zone or dead width*

For footpaths in shopping areas, an extra 1m should be added to the stipulated 4 m width. This extra width is called "Dead Width". In other situations where footpaths pass next to buildings and fences, a dead width of 0.5 m can be added. In busy areas like bus stops, railway stations, recreational areas, the width of footpath should be suitably increased to account for accumulation of pedestrian.

### 6.1.6 *Surface quality*

Firm, even paved surfaces are important to people using sticks or crutches or wheelchairs, or people walking with difficulty. The removal of obstacles like potholes, tree roots and storm water drains crossing the walkway will make it safe and usable. If brick paving is used care should be taken to lay it evenly. Where grates over storm water drains cannot be kept out of the footpath, the gratings should be aligned across the direction of travel to prevent wheelchairs' wheels from falling through. Paving should have an even surface to prevent tripping (Refer IRC:SP:50: Guidelines on Urban Drainage), and be laid to even falls to allow proper drainage and prevent the formation of puddles. The gap between paving slabs or any vertical deviation between slabs should not exceed 5 mm. **Annexure-II** may be referred for materials recommended for footpath surface.

### 6.1.7 *Cross falls*

Cross falls should only be provided where absolutely necessary for drainage purposes and should be 1:50 maximum. If the change in cross fall is so severe that one wheel of a wheelchair or one foot of a walker leaves the ground, it may cause the user of the wheelchair or walker to fall. Steeper gradients tend to misdirect buggies and wheelchairs. Where falls are not adequate, silt will accumulate after rain and cause the surface to become slippery. Puddles also cause the footpath to become slippery, lead to glare in bright sunshine after other parts of the footpath have become dry and become a hazard in frosty weather. Any break in the surface, e.g. drainage channels or the gaps between boards on a walkway, should not be greater than 12 mm and should cross perpendicular to the direction of movement. This will prevent walking sticks and wheels getting caught in the gaps.

### 6.1.8 *Service covers*

Service covers to manhole and inspection chambers should not be positioned on footpaths, particularly at dished crossings. They can be dangerous when opened for inspection, forming a tripping hazard and reducing the clear width. Covers and gratings should be non-slip, flush with the footpath surface, and be such that openings are not more than 10 mm wide. Gratings and slot type drainage should be sited away from pedestrian flows and perpendicular to the main line of pedestrian flows so as not to trap small wheels.

### 6.1.9 *Pedestrian guardrails*

Pedestrian guard-rails are an important design element to prevent indiscriminate crossing and spilling over of pedestrian on to the carriageway. Their judicious use can help to ensure that pedestrian cross the streets at predetermined and safe locations. As the guard-rails would

confine the movement of pedestrian to the footpath, it is obligatory that sufficient width of footpath be made available.

#### 6.1.9.1 Design

The design of guard-rails should be neat, simple in appearance and, as far as possible, vandal proof. Two aspects which need special consideration are the height of hand-rail and the obstruction to visibility. The height should be sufficient so as to deter people from climbing over it. The visibility of the approaching vehicles by the pedestrian as well as the visibility of the pedestrian by the drivers of the approaching vehicles should be adequate. The railings should not, therefore, have any thick horizontal member, other than the baluster to achieve the desired objective. Above all, the guard-rails should be sturdy but of slender design.

Pedestrian guard-rails in reinforced cement concrete have been found to be generally suitable in urban situations. Iron tubes, steel channelled sections, polymer fiber railings and pipes may also be adopted so as to fit in with the environment or for better aesthetics. These can, however, be costly and may also need higher level of maintenance.

#### 6.1.9.2 Applications

Use of pedestrian guard-rails should be considered under the following situations:

- (i) **Hazardous locations on straight stretches**  
In particularly busy reaches where the road is congested and vehicles move at a fast pace, guard-rails should be provided on both sides of the carriageway so as to channelize the pedestrian on to the planned crossing locations.
- (ii) **At Junctions/Intersections**  
Railing barriers should be provided to prevent people from crossing the junctions diagonally at signalised intersections. The barrier must open only at planned crossing facility (at the zebra crossing). At signalised junctions they should be provided for sufficient length to guide the pedestrian to the nearest planned pedestrian crossing.
- (iii) **Schools/Colleges**  
Provision of guard-rails near schools where children would otherwise run straight into the road is essential. If there is a pedestrian crossing or a school crossing nearby, the guard-rails must be extended up to it.
- (iv) **Bus stops, Railway stations, etc.**  
Provision of guard-rails alongside-walks with suitable access at bus stops, railway stations and other areas of heavy pedestrian activity such as cinema houses, stadiums, etc. are recommended for guiding pedestrian safely in such areas.
- (v) **Overpass, Subway, etc.**  
Guard-rails may be necessary at these locations in order to compel the pedestrian to use the facilities provided for them.

(vi) **Central reserves**

Where there is a central reserve or a median, guard-rails can be erected within it to deter the pedestrian from attempting a crossing.

## (vii) High volume pedestrian generating areas such as bus stops, markets, terminals, recreational areas, etc.

6.1.9.3 *Installation guidelines*

- Guard-rails may help to improve pedestrian safety at road intersections in cities where poor road user discipline is the cause of many accidents.
- Occasionally, gaps in guard-rails may have to be provided, to accommodate trees, pillar boxes, sign posts, electrical control boxes, etc., located near the side-walk. However, these should be suitably designed to prevent pedestrian or little children from squeezing through to cross the carriageway.
- Preferably, the guard-rails should be set back from edge of the carriageway by at least 150 mm. Railing barriers should be painted periodically, especially after the monsoon, for increased life and better appearance. Broken barriers must be promptly replaced.
- To be clearly detectable, guard-rails should be 1100 mm high from the median level and painted to contrast clearly with the surroundings preferably in canary yellow colour as it is easily detectable by persons with low vision.
- Simple galvanized railings are not desirable unless they have contrasting markings on them.
- Guard-rails on the footpath should have rounded top to prevent injuries.

Fig. 3 shows typical design of guard-rail.

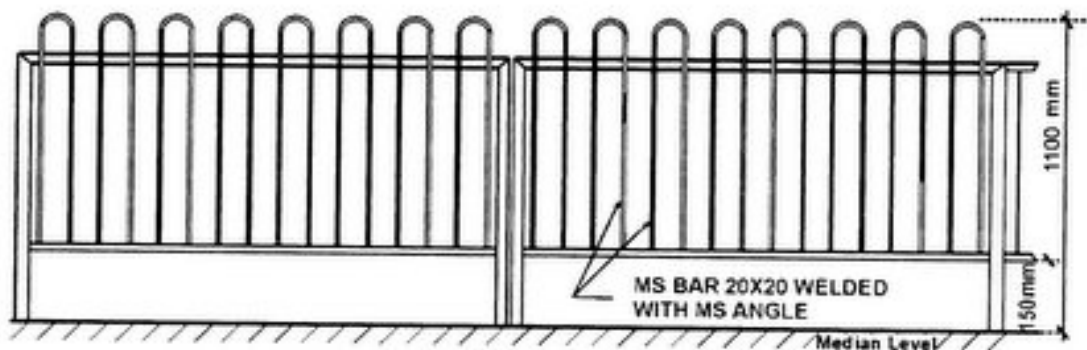

Fig. 3 Typical Design of Guard-Rail

6.1.10 *Obstructions*

6.1.10.1 Obstructions on the footpath surface shall be adequately distinguished by adopting following design elements:

- A straight shape rising from the footpath.
- A 100 mm raised platform.
- Tactile warning markings on the ground around the obstruction. The warning

markings should extend over a width of at least 600mm outside the projected area.

6.1.10.2 *Overhanging and other obstructions :*

- Obstacles (man holes, trees etc.) should be placed outside the path of travel (Fig. 4, 5) or should be placed along one continuous line.
- Overhanging signs or vegetation should be mounted at a minimum height of 2.20m.
- Undetectable obstacles mounted lower than 2.20 m may project a maximum distance of 100mm into the footpath (Fig. 7).
- Protruding elements should be avoided (Fig. 6-8). Bicycle stands should be located on a raised platform.

6.1.10.3 *Others:*

- Fixed poles should have contrasting durable colour marking strips of 300 mm in length, placed with the centre line at a height between 1.40 m -1.60 m.
- Garbage bins attached to lampposts should not face the line of pedestrian flow so as to minimize collisions and should be painted in a contrasting colour for easy identification by persons with low vision.

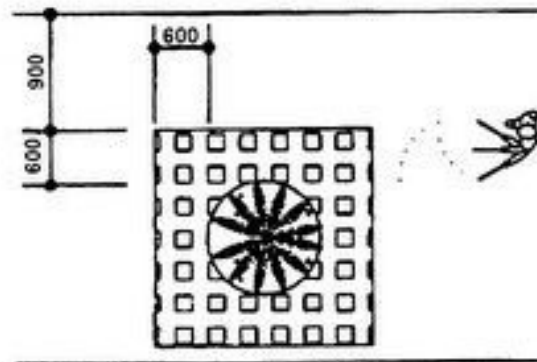

Fig. 4 Placement of Obstacles Outside Path of Travel

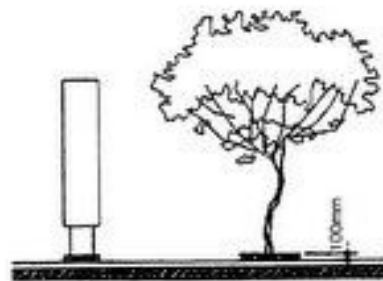

Fig. 5 Undetectable Obstacles to Project a Maximum Distance of 100 mm into the Footpath

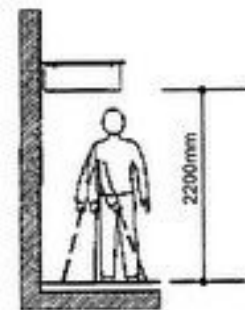

Fig. 6 Placement of Protruding Objects

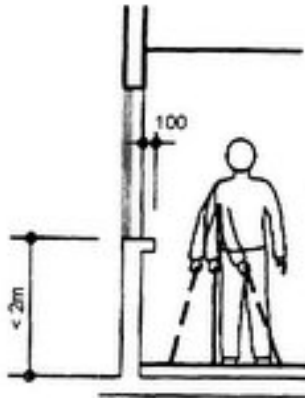

Fig. 7 Protruding Obstacles Placed in a Niche

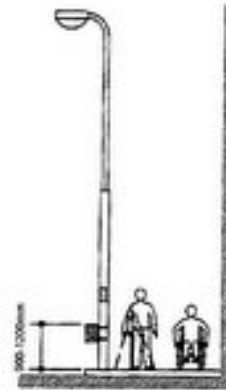

Fig. 8. Protruding Objects to be Avoided in Line of Travel

- Bollards should be painted in a contrasting colour or in coloured stripes.

## 6.2 Kerbs

### 6.2.1 Kerb height

Maximum height of a pavement (including kerb, walking surface, top-of-paving) shall not exceed 150 mm from the road level, which is the standard anthropometric height of a public step/ riser. Medians should be maximum 250 mm high or be replaced by crash barriers. Only along Segregated Busways/ BRT corridors, the kerb height of the Bus Stop could match the height of the bus floor.

### 6.2.2 Kerb radius and slip road (left turning pocket)

Smaller turning radii increase pedestrian safety in terms of reduction of crossing distances, increasing pedestrian visibility for drivers, decreasing vehicle turning speed; and making drivers look out for pedestrian while taking the turn (Fig. 9).

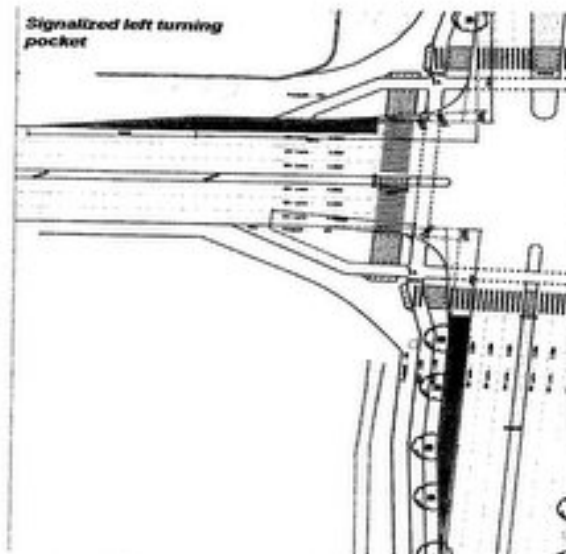

Fig. 9 Signalised Left Turning Pocket

IRC:103-2012

Maximum corner radius of kerb shall be 12 m, as this allows movement of the largest size of trucks, buses and emergency vehicles. Corner kerb radius may be reduced to 6m in residential areas to slow down turning buses, trucks etc. with the provision of a mountable kerb for turning of emergency vehicles.

Left Turning Slip roads provided at road junctions are meant for signal free movement of vehicular traffic. However, such left turning slip roads may make crossing by pedestrian and cyclists unsafe in case of high volume of left turning vehicular traffic. Therefore, from safety of pedestrian and cyclist standpoint, slip roads are not desirable.

Slip roads or Free Left Turns should be avoided at intersections up to right of way of 30 m. In cases where they already exist for intersections of roads with right of way more than 30 m, following strategies may be employed:

- Slip roads are not recommended wherever crossing pedestrian and NMV volumes are high. In such situations corner radius of kerb can be reduced to slow the movement traffic. The slip road crossing can be signalized fully or pelican signal may be provided.
- Signalized turning pockets may be provided where left-turning volumes are high. Raised table top crossings (**Photo 1**) may also be introduced and shall invariably be provided at slip roads, with a minimum 20-second pedestrian signal, to allow pedestrian and cyclists to cross the road safely and comfortably at the same level. Table top with flat surface will be preceded followed by the gradient at 1:15



Photo 1 Raised Table Top Crossing

### 6.2.3 Kerb ramps

Kerb ramp is useful for a smooth transition, to overcome changes in level between the footpath and the road carriageway, at each pedestrian crossing on opposite sides of the street and in the vicinity of building entrances. Absence of kerb ramps prevents persons with disabilities and reduced mobility from crossing streets.

- Standard kerb ramps are cut back into the footpath (flush with roadway), at a gradient not greater than 1:12 (Fig. 10, 11 & 12), with flared sides providing transition in three directions. At street intersection and turnings kerb ramps should be provided (Fig. 13, 14 & 15).
- Width of the kerb ramp should not be less than 1200 mm.
- Tactile warning strip shall be provided on the kerb side edge of the slope, so that persons with vision impairment do not accidentally walk onto the road.
- The ramps should be flared smooth into the street surface and checked periodically to make sure large gaps do not develop between the gutter and street surface.
- It is desirable to provide two kerb cuts per corner. Single ramp located in the center of a corner is less desirable. Separate ramps provide greater information to pedestrian with vision impairment in street crossings.

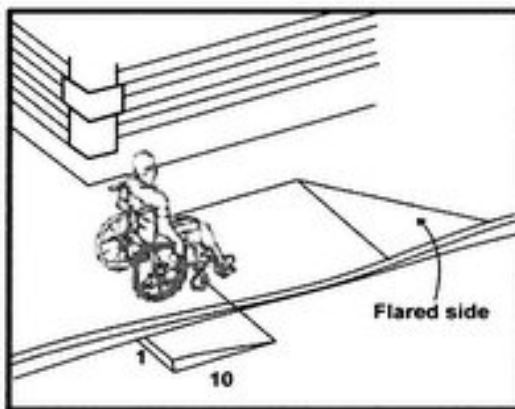

Fig. 10 Kerb Ramp

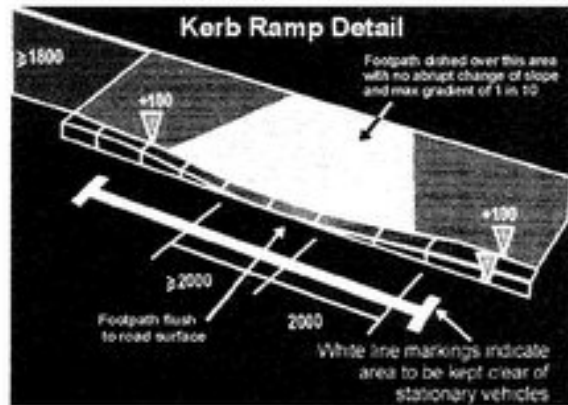

Fig. 11 Kerb Ramp Detail

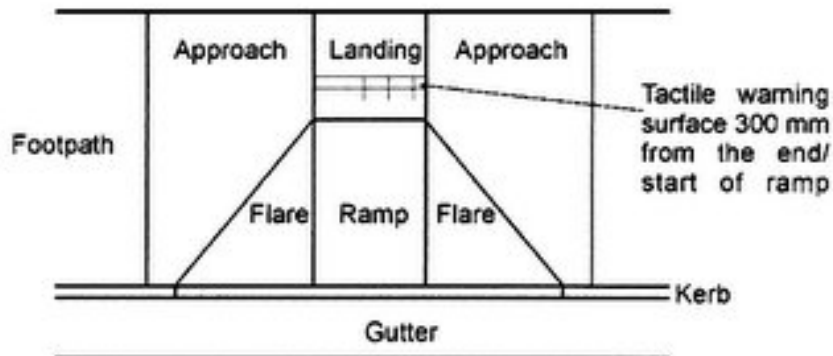

Fig. 12 Kerb Extension at Street Intersection



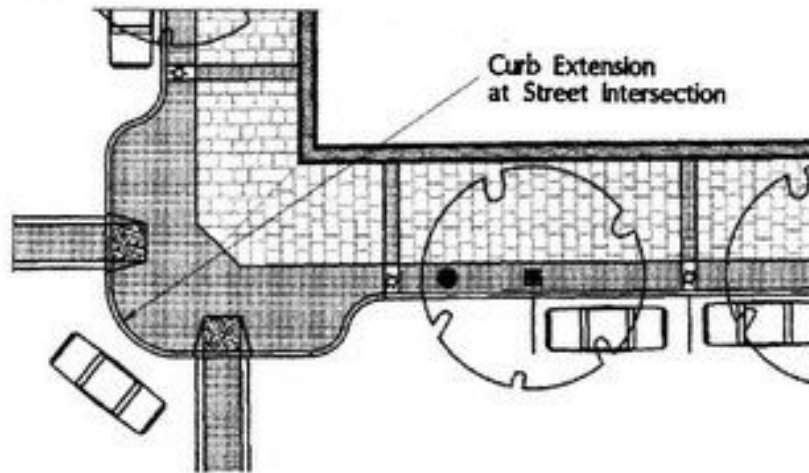
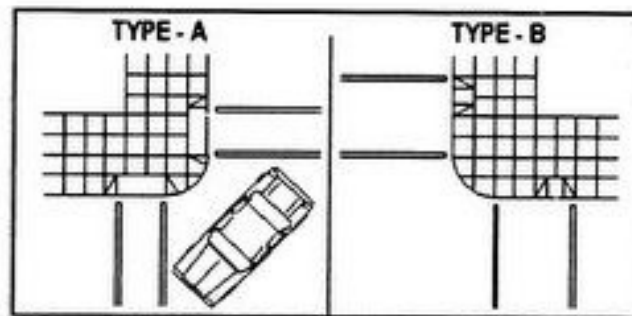
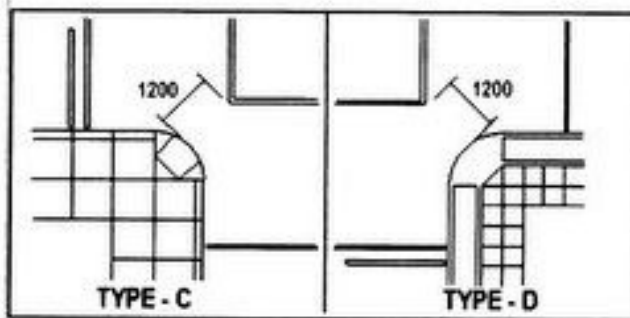

Fig. 13 Recommended Design for a Kerb Ramp



**Desirable**



**Undesirable**

Fig. 14 Kerb Placements at Turnings

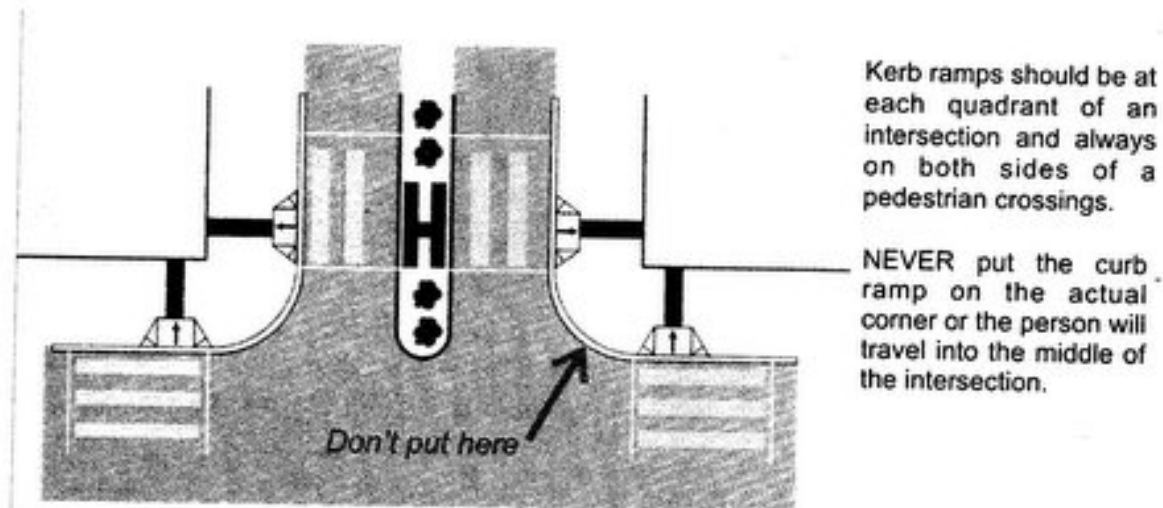

Fig. 15 Plans of Kerb Ramps at Intersections

### 6.3 Continuity and Consistency

It is mandatory for footpaths to be continuous between junctions or where at-grade crossing is provided. A change in colour of pavers can emphasize and highlight the crossing area to all users. Consistency of design elements, color and texture should provide visual continuity. Footpath interruptions must be avoided by minimizing cuts in kerbs. These act as traffic calming measures and make such conflict points safer. Entrances/exits, side properties, gates and service lanes shall be accommodated by following provisions:

- Raised crossings, where the car lanes are raised by ramps of slope (1:10) and brought to the level of the footpath (+150 mm from carriageway).
- The pavers on the footpath should continue over the raised crossings with vehicle load taken into account for the area subjected to vehicular traffic.
- Minimize the number of driveways crossing the footpath should be minimized to support pedestrian safety and continuous footpath.
- The continuity of footpath in the public right-of-way (**Photo 2**) should be maintained, incorporating existing wall openings, steps and other features that might obstruct the walkway.
- Connections for missing links should be provided by installing footpath to connect pedestrian areas to each other.
- Every change in level on the footpath (steps, kerbs or road-works) should be made clearly visible through the use of bright contrasting colours and tactile pavers for persons with low vision and vision impairment.



Photo 2 Continuity in Pedestrian Track

#### 6.4 Tactile Pavers

6.4.1 Usually persons with vision impairment need guidance in using a pedestrianised area, especially if the footpath crosses larger open spaces where the usual guidance given by the edge of the footpath or building base is not available, or when pedestrian need guidance around obstacles. It is important that, whichever tactile pavers are used for guiding or warning, they should be used consistently to avoid confusion. The different texture can be followed by people using a long or white cane, and can also be detected underfoot by others with low vision.

6.4.2 Guide blocks (Line blocks, Fig. 16) has straight continuous line and indicate the correct path/route to follow, leading to building entrances, an amenity, bus stop etc. It should be laid in a simple and logical manner and not be located close to manholes or drains, to avoid confusion for persons with vision impairments. A continuous path of guide blocks in the direction of pedestrian travel, which has a different texture to the rest of the footpath, can provide this guidance.

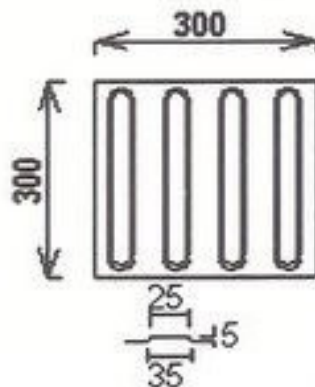

Fig. 16 Guiding Blocks

**6.4.3** Warning blocks (Dot/Blistered block, Fig.17) provides warning signal to screen off obstacles, drop-offs or other hazards, to discourage movement in an incorrect direction and to give warning of a corner or junction. It should be placed 300 mm at the beginning and end of the ramps, stairs and entrance to any door. It should be laid 600mm wide across the entire footpath where the crossing occurs. Provide a warning block strip along the inner edge of a footpath where there is a break in the line of the corridor, e.g. at a garage forecourt or a gap in a building façade for an archway. Tactile paving at intersections, turnings, building entrances, etc. should be provided (Fig. 18).

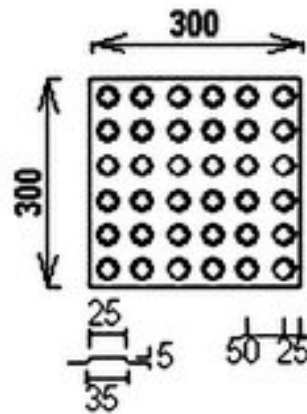

Fig. 17 Warning Blocks

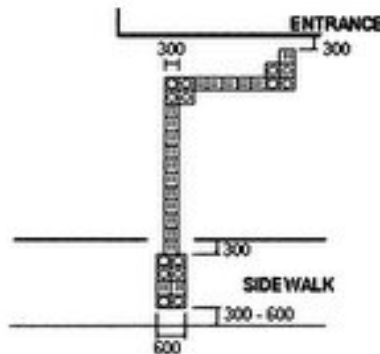
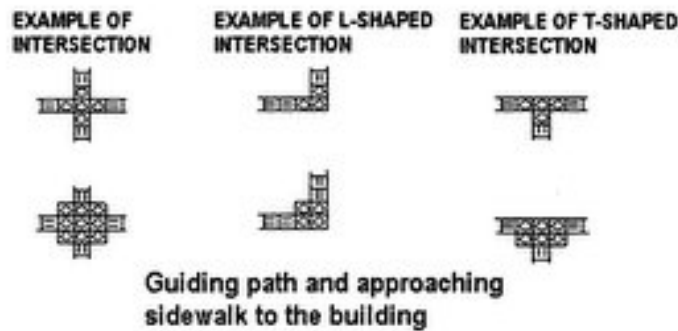

Fig. 18 Configuration of Floor Tactile Paving

IRC:103-2012

These tiles should have a colour (preferably canary yellow), which contrasts with the surrounding surface. Tactile paving must, however, be maintained to ensure that the profile does not erode away. This will allow persons with visual impairments to recognize that they are continuing in the right direction and that they have not reached a junction or missed a turning. A distance of 600 mm is to be maintained from the edge of footpath/ boundary wall/ any obstruction to navigate persons with vision impairment (Photo 3, 4 and 5).



Photo 3 Configuration of Floor Tactile Paving



Photo 4 Tactile Paving in the Line of Travel Avoiding Obstructions



Photo 5 Tactile Paving on Footpath Leading to Ramp and Crossing

Tactile paving should be provided in the line of travel avoiding obstructions such as manholes/ tree guards/lamp posts etc. and also at raised crossing (Fig. 19)

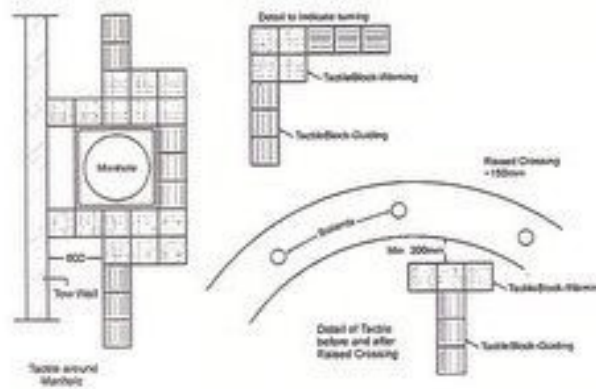

Fig. 19 Tactile lay out for Manhole and Raised Crossing

## 6.5 Level Change

It may be possible to adjust ground levels more broadly to eliminate the need for a ramp or steps altogether. Arbitrary changes of level should be avoided. For instance, in creating a sense of importance for a building approach, a change in the quality of paving or street furniture can have the desired effect, rather than introducing a level change.

- A ramp or series of slopes should be integrated into the level change to facilitate wheelchair users or pram/buggies and bi-cycles (Photo 6).
- The steeper the incline, ramp or steps, and the greater the change in level, the more frequent is the need for landings and resting places.
- Where resting places are located on landings, they should be out of the way of the line of movement. A gradient less than 1:20 does not require handrails and resting places.
- A gradient of 1:10 or steeper will be extremely difficult and dangerous for most persons with disabilities to use. This is the point in the natural landscape where accessibility, particularly for those with mobility impairments, will become an issue for assistance and/or special provision. At these gradients, many persons would welcome a place to rest which is desirable at suitable places.



Photo 6 Levelled Crossing Over Cycle Track, BRT Corridor, New Delhi

## 6.6 Maintenance

Regular maintenance of footpath will ensure uninterrupted accessibility. Maintenance should prevent or replace cracked and uneven paving slabs and those with loose joints, as they become tripping hazards and are difficult to walk on. They also cause puddles to form and can become slippery. The selection of paving materials should therefore be guided by the ease of repair and maintenance. These should be regularly checked before, during and after rains.

## 6.7 Pedestrian Crossings

### 6.7.1 Principles of pedestrian crossings

- Pedestrian must be given the shortest possible direct route to cross the street; therefore the most preferred crossing for them is "at-grade".
- Mid Block Crossings must be provided for people to cross the street safely between building entries or bus stop locations or active land uses on opposite sides of the street.
- Crossings must be provided at all T-junctions.
- At grade pedestrian crossing both near intersection and mid-block, raised pedestrian crossing (table top) should be made mandatory in case of multilane roads with heavy volume of vehicular traffic.

### 6.7.2 Key guidelines

- Minimum 3 m wide pedestrian crossing and 2.5 m wide cycle crossing must be provided at all road crossings.
- All crossings should have universal accessibility features (for persons with disabilities, reduced mobility, vision and hearing impairment) and street directional signage.
- At-grade crossings are preferable in pedestrian priority areas and streets.
- If grade separation is required in a high pedestrian and NMT priority zone (e.g. near Metro or BRT stations), the pedestrian and NMT must be kept at grade.
- Midblock crossing kerb extensions provide better visibility for motorists and pedestrian (**Fig. 20**). This kind of kerb extension of the street will be provided whenever the street is characterised by kerb side parting facility.
- A midblock crossing with a median refuge allows the pedestrian to look for gaps in only one direction at a time (**Fig. 21**).

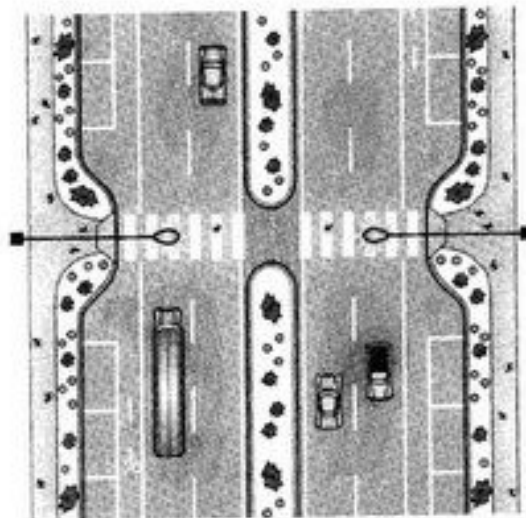

Fig. 20 Midblock Crossing Kerb Extensions

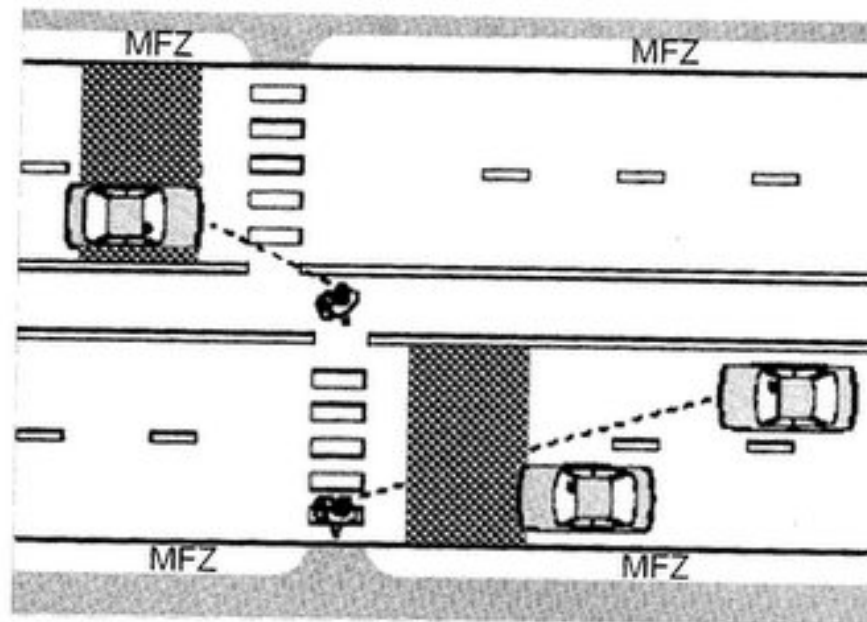

Fig. 21 A Midblock Crossing with a Median Refuge

- Mid-block crossings must be provided at regular intervals (Table 3)

Table 3 Standards for Mid-Block Pedestrian Crossing

• Residential Areas	<ul style="list-style-type: none"> <li>• Spacing Range: Every 80–250 m</li> <li>• Coordinated with entry points of complexes; location of bus/ train stops, public facilities, etc.</li> </ul>
• Commercial/ Mixed Use Areas	<ul style="list-style-type: none"> <li>• Spacing Range: Every 80–150 m</li> </ul>
• High Intensity Commercial Areas	<ul style="list-style-type: none"> <li>• Pedestrianization if possible.</li> </ul>

- Crossing roads is one of the major deterrents to pedestrian with disabilities and reduced mobility. At main crossing points, kerb ramp should be provided to facilitate persons with buggies or using wheelchairs. Kerb ramps should be located away from corners, on both sides of the street, flush with the road.
- With crossings at grade, pedestrian experience a continuous pathway that will connect them with different destinations, including transit stations and commercial districts, safely.
- Kerbs are the best indicators for persons with vision impairments to detect the edge of the footpath. So kerb ramps/footpath must always have tactile pavers/tiles with flared sides of 1:10 gradient (Fig. 22). Kerb ramps should be 1200 mm, minimum 900 mm wide. The gradient of the ramp should ideally be 1:20, and not to exceed 1:12 in any case. It can be difficult in existing situations to achieve a dropped kerb with a gradient of 1:20 across a footpath and still leave a clear corridor of movement along the footpath. For persons with visual impairment, crossing should be marked with tactile paving.



- Different materials should also be used to indicate the change in function between the footpath and carriageway.
- Make sure the crossing point is always well drained. Avoid gullies in the immediate area of the crossing. However, the slight kerb lip required to facilitate roadway drainage should be maximum 20mm high and chamfered in section.
- Raised crossings for pedestrian footpath across property entrances, petrol pump entrances, minor roads, service lane access and un-signalized intersections should be provided.
- In busy streets, safe crossing areas with pedestrian operated traffic signals should be provided.
- Audible crossing signals (pelican crossings) help everyone, as well as being essential for persons with vision impairments. Pedestrian traffic lights should be provided with clearly audible signals to facilitate safe and independent crossing of pedestrian with low vision and vision impairment. Acoustic devices should be installed on a pole at the point of origin of crossing and not at the point of destination.

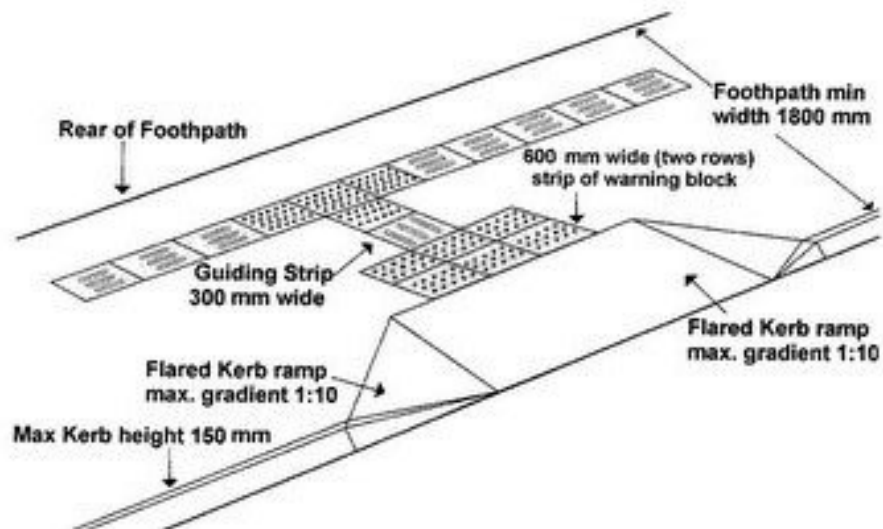

Fig. 22 Kerb Ramp with Flared Sides and Tactile Pavers

### 6.7.3 Components of pedestrian crossings

#### 6.7.3.1 Zebra crossing

A zebra crossing is a clearly specified pedestrian track across the carriageway and is delineated with the help of alternate black and white stripes, which should have embossed texture for easy detection by persons with vision impairment. Thermoplastic paint with + 5 mm embossed texture can be used and raised pedestrian crossings (table top) be provided (Photo 7). Alternatively dropped kerb can be provided (Fig. 23). A zebra crossing must always be accompanied by a "STOP" line as per IRC:35-1970 'Code of Practice For Road Markings (First Revision)'.



Photo 7 Raised Pedestrian Crossings (Table Top)

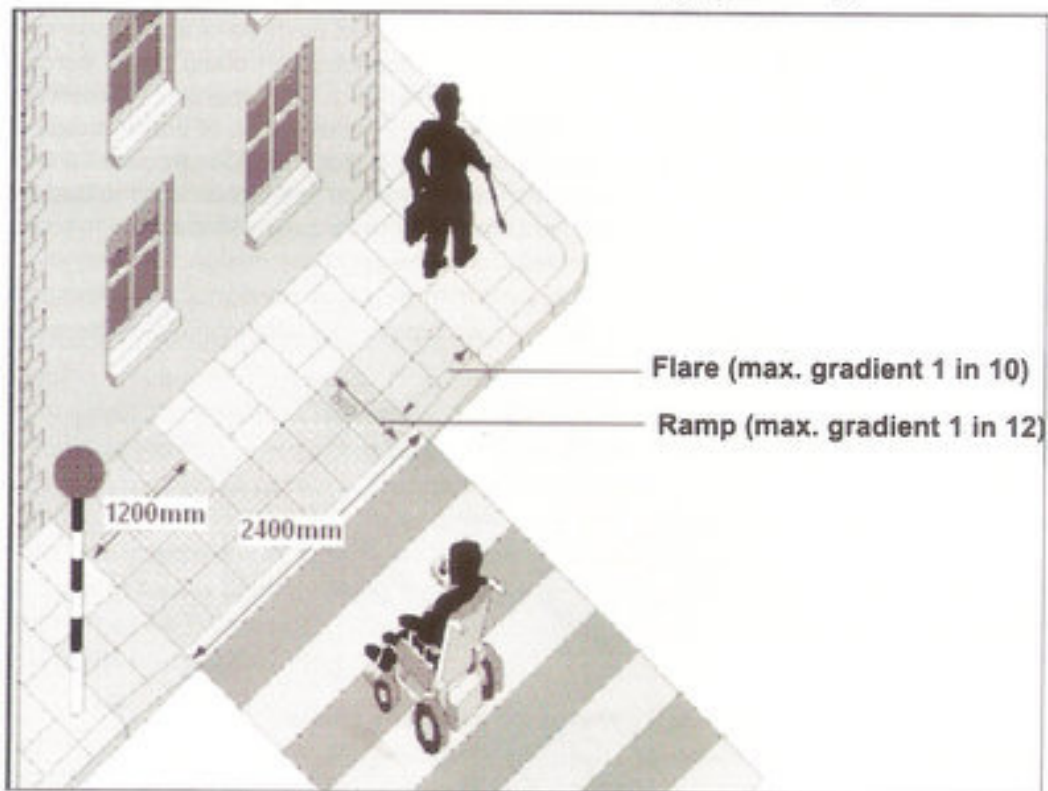

Fig. 23 Dropped Kerb with Raised Crossings

**Siting of zebra crossing:** A zebra crossing should not be sited within 150 m of another such crossing. Provision of zebra crossings at short intervals adversely affects the overall efficiency of traffic operation in the area. For safety reasons, the zebra crossing should be somewhat set

back from the carriageway line. However, the setback distance should not be so much as to cause an appreciable increase in walking distance for the pedestrian. Pedestrian guard-rails may be necessary where the setback distance is appreciable or at the skew crossings.

**Width of zebra crossing:** The width of the zebra crossing must be adequate and should generally lie within a range of 2-4 m. For divided carriageways, the crossing should, as far as possible, proceed uninterrupted through the median strip. In the event of the median strip being used as pedestrian refuge, adequate width of median must be provided. In case of raised medians, such portion could be suitably depressed with kerb height not exceeding 150 mm.

**Guard-rails and lighting:** Guard-rails in the vicinity of zebra crossing should be of sufficient length to deter pedestrian from crossing the road at any arbitrary point along the road. Night time visibility of zebra crossing is of vital importance and this can be achieved through proper lighting of the intersection area.

**Zebra crossing at signalized intersections:** Unlike in the case of un-signalized intersections where the pedestrian uses the zebra crossings through judicious gap selection, a signalized intersection could allow exclusive time slots for movement of cross pedestrian traffic. In the case of intersections controlled by two phase signals, an "all red" phase could be inserted to ease pedestrian movements. In case of intersections controlled by three or four phase signals, zebra crossings could be utilized in such a manner that pedestrian could move across the road in a direction parallel to the movement of vehicular traffic during a particular green phase. If exclusive time slots for movement of pedestrian is not available, use of zebra crossings at such locations would also warrant judicious gap selection. It is a good idea to install a flashing warning signal for pedestrian and left turning vehicular traffic at such intersections that permit uninterrupted infiltration to the left for vehicular traffic. Wherever pedestrian signal is provided, Stop Line should be provided to stop the vehicles. The physical design features of zebra crossings at signalized intersections will be similar to those at un-signalized intersections. **Fig. 24** shows zebra crossings and other details for a typical four arm signalized intersection.

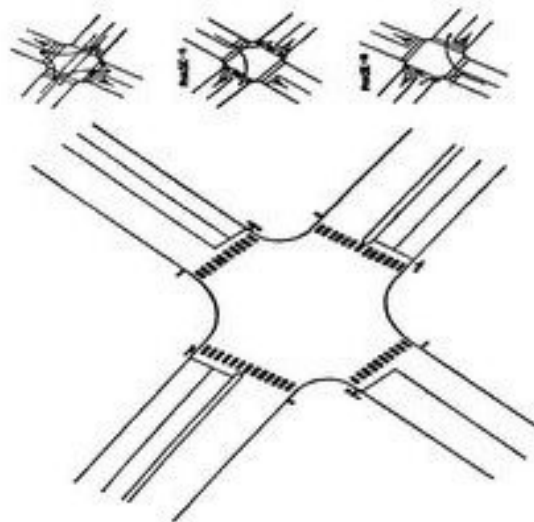

Fig. 24 Type Design of Four Arm Intersection Showing Zebra Crossing and Pedestrian Phases

### 6.7.3.2 Traffic signal

Keeping in mind the volume of pedestrian traffic, general design criteria for signalized crossings on different rights-of-way are as under:

R/Ws $\leq$ 30 m	A Pedestrian cycle should be added to all at-grade signalized crossings. At mid-block, signalized pedestrian only crossings need to be provided as required.
R/Ws above 30 m	Separate pedestrian cycle is not necessary at all at-grade signalized crossings. However, Median Refuge Islands as per Fig. 21 should be provided at all signalized crossings and mid-block pedestrian only crossings.

In a traffic signal, the red phase should keep traffic stopped for minimum 12 seconds for a 7.5m crossing to allow disabled pedestrian to complete their crossing. Signals that can be activated by the pedestrian using a push button box (Pelican signal) are useful, particularly at mid-block crossings. A large diameter (up to 50 mm) raised button that can be activated by a closed fist will be usable by most people. Traffic signal poles and push buttons should also be colour contrasted. At signalized intersections audible signals can be very useful to pedestrian with vision impairment. Audible signals may encourage safer crossing behavior among children. These signals have a beep which sounds during the first part of the green phase to indicate when it is safe to cross the road. To help pedestrian with vision impairment, the push button box should be located consistently at crossings. The push button box should have Braille buttons and raised alphabets for different signals, for example 's' for stop and 'g' for go and so on. It is also important to place the traffic signal in conformity with pedestrian sign (Refer IRC: 67- 2010:Code of Practice for Road Signs (Second Revision)) to enable pedestrian to cross the road in safer manner. Also, variable message signage including the options of pedestrian timing can be displayed.

### 6.7.3.3 Refuge islands

The provision of pedestrian refuges and traffic islands is a useful traffic management technique on pedestrian routes near junctions or roundabouts enabling the pedestrian to deal with one lane particular direction of traffic at a time. Pedestrian refuges are, an effective way to help disabled and elderly pedestrian. They do reduce pedestrian accidents. This should be mandatory on all roads with four lanes or more. Traffic islands and medians should be adequate in size to accommodate the length of a pram or wheelchair and pusher. The recommended width is, therefore 2 m (Table 4). At staggered pelican crossings including those without guardrails, two courses of tactile paving linking the two kerb edges should be provided with the rest of the central reserve paved normally. Traffic islands and medians should be accompanied by dropped kerbs on both footpaths.

**Table 4 Width of Pedestrian Refuges**

Medians (Pedestrian Refuge/Island)	
Width of Median	Absolute minimum 1200 mm
Centre of a staggered crossing	Minimum clear width between guard rails 2 m to allow two wheelchair users to pass one another.

The safety of pedestrian is enhanced by the provision of pedestrian refuge islands on roads having wide carriageway (Fig. 25 & 26). The main function of a refuge island is to provide a place of safety for pedestrian who cannot cross the entire carriageway at one time in safety. At-grade Median Refuges allow pedestrian to wait safely for crossing wide streets with long signal rotations (Photo 8 & 9). The best use of medians is planting of trees and bioswales to create on conducive temperature for the street & increasing its ecological value by treating and filtering storm water on site. Medians can be designed to retain, cleanse, and infiltrate storm water runoff from the road way, replenishing ground water and decreasing the peak flow burden on storm water infrastructure.

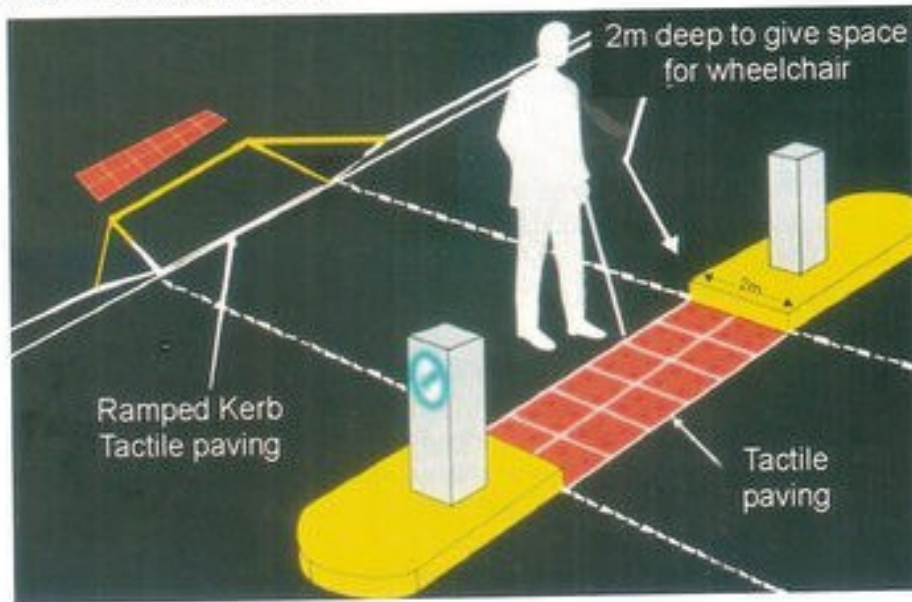

Fig. 25 Pedestrian Refuge on Two Way Road

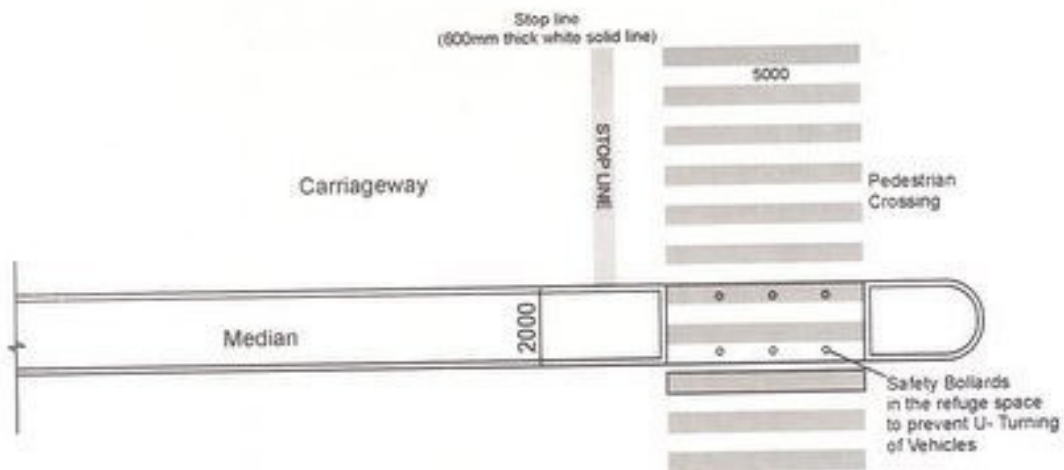

Fig. 26 Pedestrian Refuge on Two Way Road



Photo 8 Median Pedestrian Refuge on Two-Way Road



Photo 9 Median Pedestrian Refuge at Signal-Controlled Junction

#### 6.7.4 *Types of pedestrian crossings*

Pedestrian cross-walks should be provided at all important intersections and such other locations where substantial conflict exists between vehicular and pedestrian movements. Wherever possible the cross-walks should be at right angles to the carriage-way and properly marked so that the pedestrian are subjected to minimum inconvenience. Cross-walks should not substantially increase the walk distance for pedestrian. Adequate visibility, freedom from obstructions and sufficient space for waiting are the other important requirements for location of cross-walks. Pedestrian crossings can be broadly classified as:

- (a) At-grade crossings
- (b) Grade separated crossings

#### 6.7.4.1 At-grade pedestrian crossings

At-grade pedestrian crossings are those where the pedestrian cross the carriageway at the same level as that of vehicular movement. Grade separated crossings are those where the pedestrian are required to cross the carriageway at a level different from that of vehicular movement. Thus, the latter may be in the form of a pedestrian subway or a foot over bridge across the road. At-grade pedestrian crossings are of common occurrence in cities and towns. With respect to locational aspects, such crossings could be classified as:

- (i) Pedestrian crossings at intersections
- (ii) At-grade pedestrian crossing away from intersection (e.g. mid-block crossings).
- (iii) At-grade pedestrian crossing at Intersections could be uncontrolled or controlled.
  - **Uncontrolled crossings** are those where the pedestrian cross-walk is marked by studs or paint line but not controlled by any system of signals. Provision of uncontrolled pedestrian crossings must, as far as possible, be avoided except where the intersection itself is left uncontrolled because of extremely low volumes of both vehicular and pedestrian traffic even during peak hours and where accident records do not indicate any need to segregate vehicular traffic from cross pedestrian traffic.
  - **Controlled crossings** are achieved normally through provision of zebra crossings whether at an unsignalized or signalized intersection. Once a pedestrian is on a zebra crossing, she/he gains priority of movement with respect to vehicular traffic. Pedestrian crossings must inevitably be integrated with the overall design of the intersection.

**6.7.4.1.1 Uncontrolled crossings:** Mid-block zebra crossings are to be provided only when the distance between two consecutive intersections is more than 300 m and simultaneously, there is a genuine demand for such a facility (e.g. shopping or commercial area being located within this area).

It must be noted that mid-block crossings are more difficult to control and frequently warrant provision of additional safety measures. All such crossings must be properly maintained with respect to painting, marking, etc., and must always be accompanied by suitable "pedestrian cross" signs. These signs must be so located that their visibility is not impaired by road side trees, overhead service poles, bends, humps or any other physical obstruction. For undivided carriageways, mid-block crossings should be accompanied by "STOP" lines with central barrier line marking being continued on either side of the crossing up to a certain distance on each side. **Fig. 27** shows a typical layout plan for such a crossing. In case of two way streets, the "STOP" line will be on one side of the crossing only as shown in, **Fig. 28** Beacons or flashing signals may be used with advantage in conjunction with pedestrian cross signs at such locations. In the case of mid-block crossings, the guard-rail must open at the crossing only. Guard-rails are rather essential for satisfactory operation of mid-block crossings. All other physical design considerations in this case remain same as in the case of zebra crossings at intersections.

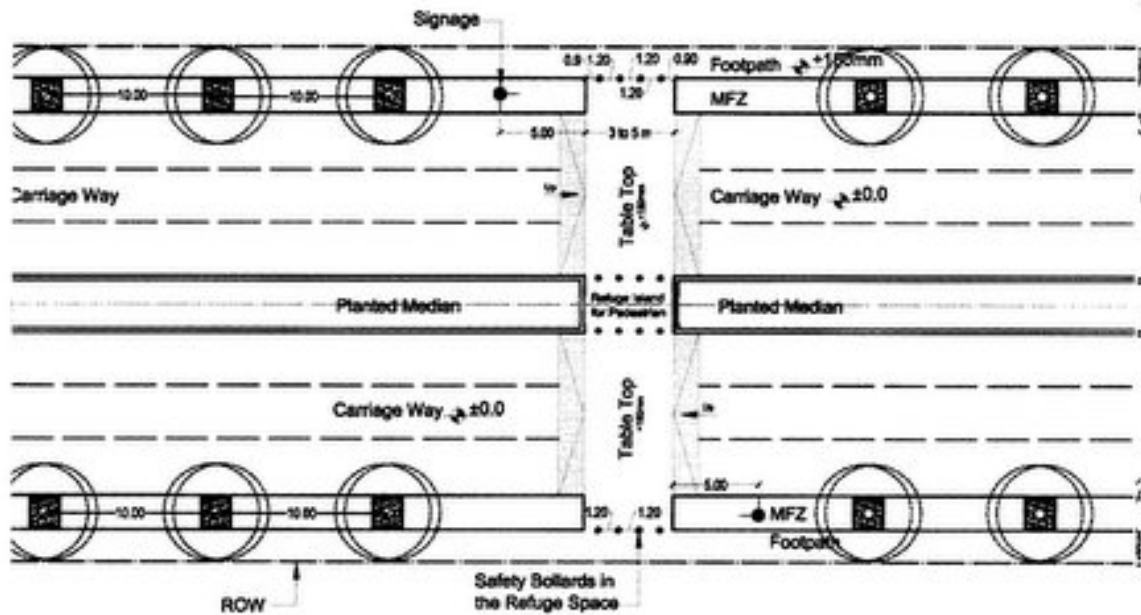

Fig. 27 Mid-Block Uncontrolled Crossing Across Two-Way Street

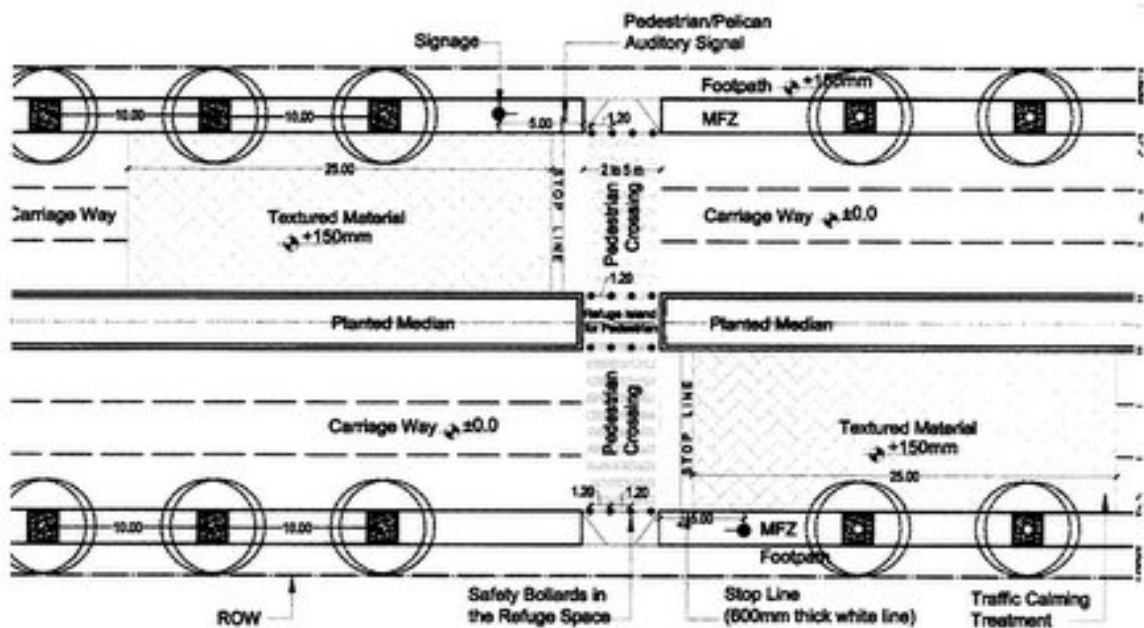

Fig. 28 Mid-Block Controlled Crossing Across Two-Way Street

6.7.4.1.2 *Controlled crossings:* Control measures at mid-block crossings may be warranted when one or more of the following conditions exist:

- (i) Peak hour volumes of pedestrian (P) and vehicles (V) are such that  $PV^2 > 10^8$  for undivided carriageways and  $PV^2 > 2 \times 10^8$  for divided carriageways;
- (ii) Approach speeds of vehicles exceed 65 kph;



- (iii) Waiting time for pedestrian/vehicles becomes too long;
- (iv) Accident records indicate 5 or more injuries to pedestrian in a year due to collision with vehicles.

The control measure usually adopted in such cases is a traffic signal with exclusive pedestrian phase. In certain cases, where the warrants are met only during peak hours, police control could also be introduced. Pedestrian operated pelican signals could also be introduced at such locations where the vehicular volume is too large even though the volume of pedestrian may be low. Unless judiciously used, pelican crossings are known to cause undesirable impediments to the flow of vehicular traffic.

The design of street crossings should aim for simplicity and consistency. The recommended minimum width of a street crossing is 1800 mm. Where the pedestrian has to cross multiple lanes of traffic, central islands are extremely helpful because they reduce the distance that the pedestrian have to walk on the road at one time without protection. Central islands convert two-way roads into two separate one-way roads, which are much easier to cross. They can also help slow the movement of traffic and reduce vehicle speeds. Centre islands should be at least 2 m wide across the direction of the road to cater for wheelchairs, with a cut through at the surface level of the crossing, preferably 5 m wide along the length of the road.

The safety of a crossing can be significantly improved by extending the footpath out across any parking lanes (**Fig. 29 & Photo 10**). This has the triple purpose of reducing the width of roadway to be crossed, slowing vehicular traffic and improving the ability of pedestrian and drivers to see each other. Crossings should be laid out with ample space, especially at the top of the kerb ramp to allow easy passage for pedestrian who are not crossing the road.

It is important to design crossings with consistent patterns, to enable visually impaired users to orient themselves easily. For instance, the traffic signal pole should always be on the left (or the right) of the crossing; and the push button at the same height (about 1000 mm above the ground). With respect to design speed to be considered at crossings, the following are recommended

- 15<sup>th</sup> percentile speed (approx. 0.95 m/s) should be used for the design of pedestrian crossing facilities
- If older pedestrian are high in proportion a crossing speed of 0.79 m/s should be used
- In educational and recreational areas it can be taken as 0.98 m/s

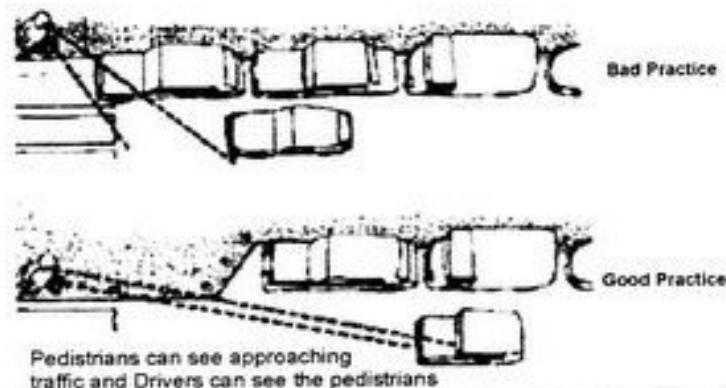

Fig. 29 Extending the Footpath out Across Parking Lanes at a Crossing



Photo 10 Example of Extending the Footpath at a Crossing

#### 6.7.4.1.3 Pedestrian safety at roundabouts

Roundabouts are used at intersections in place of signals and can handle significant traffic volumes. Although their primary purpose is to provide free flowing mobility to motor vehicles, properly designed roundabouts can create a positive environment for pedestrian, as well as a unique design treatment. Roundabouts have lower vehicle speeds and fewer pedestrian collisions than standard signalized or unsignalized intersections, and experience has demonstrated that vehicular crashes are significantly reduced when low-speed, single lane roundabouts replace four-way intersections<sup>1</sup>.

When vehicular volumes are low to moderate, roundabouts allow pedestrian to cross frequently without waiting for vehicles to stop. However, crossing pedestrian are not protected since vehicles are free flowing. Modern roundabouts incorporate splitter islands to provide crossing refuge for pedestrian and deflect the path of motor vehicles. This deflection reduces vehicle speeds making it easier for pedestrian to cross. Because they introduce non-standard geometry to the intersection, roundabouts can be confusing to pedestrian with visual impairments and special care must be taken to provide way finding cues such as tactile pavers/ audio cues.

Roundabouts are safer for pedestrian than conventional intersections. Pedestrian generally walk on footpaths around the perimeter of the circular roadway and roundabout. If they require traveling across the roadway, they move across only one direction of traffic at a time. In addition, crossing distances are relatively short, and traffic speeds are lower than at conventional intersections.

Studies indicate that, on average, converting conventional intersections to roundabouts can reduce the magnitude of pedestrian crashes by about 75 percent. Single-lane roundabouts,

<sup>1</sup>*Context Sensitive Solutions in Designing of Major Urban Thoroughfares for Walkable Communities, Institute of Transportation Engineers Proposed Recommended Practice*

in particular, have been reported to cause substantially lower pedestrian crash rates than comparable intersections with traffic signals. Roundabouts have fewer conflicts.

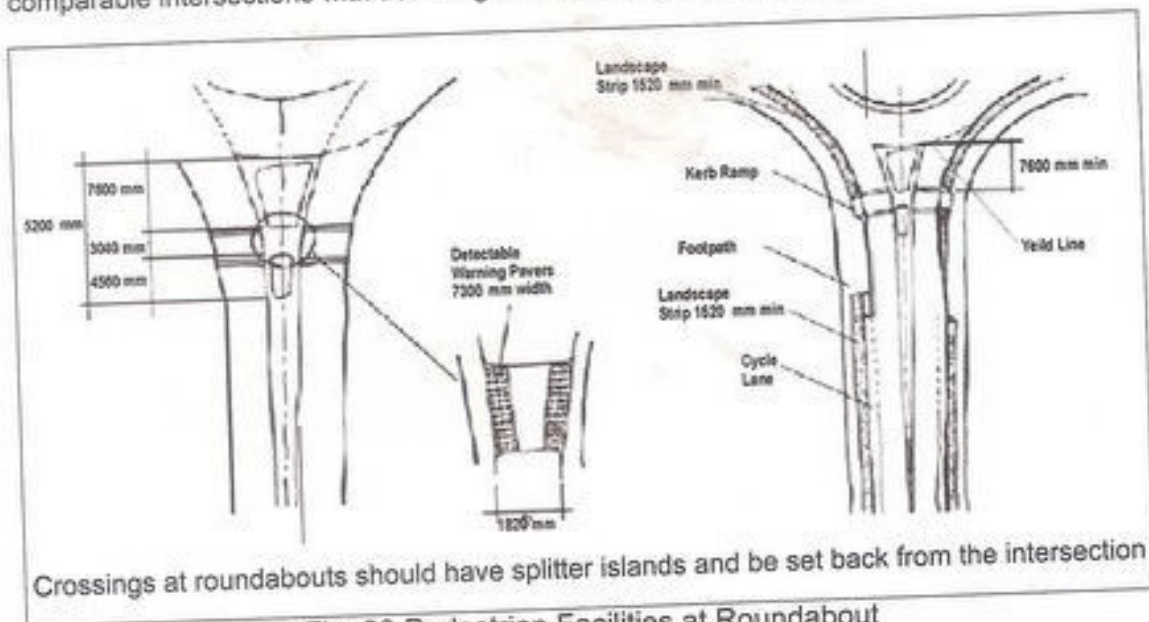

Fig. 30 Pedestrian Facilities at Roundabout

For example, any four legged uncontrolled junction offers 32 vehicle-vehicle conflicts and 24 vehicle-pedestrian conflicts while round about only offers 8 vehicle-vehicle and 8 vehicle-pedestrian conflicts. Only Multi-lane roundabouts present some challenges to pedestrian, thus reducing the safety effects. Fig. 30 & 31 and Photo 11 shows pedestrian facilities at round-about in which all the approach arms can be used to provide zebra crossings with table top facilities.



Fig. 31 Pedestrian Facilities at Roundabout



Photo 11 Kerb Ramps and Crossings at Roundabouts

#### 6.7.4.2 *Grade separated pedestrian crossing facilities*

##### 6.7.4.2.1 *Warrants*

Provision of a grade separated pedestrian facility may be warranted at locations where one or more of the following conditions exist:

- (1) Volumes of pedestrian and vehicular traffic are so large that insertion of an exclusive pedestrian phase will increase the cycle time for traffic signals beyond 120 seconds;
- (2) Vehicular traffic demands uninterrupted flow as associated with major arterial roads and expressways;
- (3) Control at-grade pedestrian crossing decisively fails to mitigate the problems of pedestrian-vehicle collision. Viability of a grade separated pedestrian facility must be checked against delay costs for both pedestrian and vehicle drivers/users including increase in vehicle operating costs inflicted by increased delays. Effective law enforcement is necessary to control incidental crossing of Stop line by vehicles.

##### 6.7.4.2.2 *Layout of grade separated pedestrian facilities*

Most pedestrian consider that the shortest and quickest way to cross a road is at grade (at level) – in the absence of traffic. This perception is heightened under mobility impairment. The reasons are various, for instance, tortuous routes confuse blind people, additional distances hamper frail people, steps, escalators and steep ramps are problematic, if not physically impossible, to several groups. Descending into badly lit, insanitary subway is unpleasant, as well as adding to fears (real or imaginary) of being attacked especially to children, girls and women with disability.

**Hence, at grade pedestrian crossings** are the shortest, quickest and the most comfortable way to cross a road by any pedestrian. The ideal situation is one where the pedestrian does

not have to change level and this should be seriously considered in planning new facilities. If this cannot be achieved, the height that the pedestrian must rise or fall should be minimized. Generally, a subway more easily solves this problem than a FOB, as the headroom to be accommodated is less. The layout of the flyover is so prepared that it does not end at preferred mode of crossing nor embankment falls in the preferred mode of crossing. Elevated portion may be extended or pedestrian subway should invariably be planned through the embankment. Table 5 gives requirements of pedestrian subways.

**Table 5 Requirements of Pedestrian Subway**

Pedestrian Subway	
Width	4.8 m
Vertical clearance	2.75 m
Visibility	There should be a clear view from one end to the other and a good level of lighting, at least 50 lux.
Security	CCTV cameras placed in subways will enhance security and should be located so as to provide full coverage. Notices to the effect that CCTV is in operation should deter vandals and provide a measure of comfort to pedestrian. Small shops shall be encouraged and set up as it gives sense of safety to pedestrians during night time also.

Options given below are prioritized in order of pedestrian friendliness:

- Hump subways:** Both the car lane users and the pedestrian (including cyclists, wherever segregated facility is provided) need to have a change in level. The surface of the road is raised (+1.5 m) using a ramp of 1:30 and the pedestrian paths (cycle tracks, wherever provided) are lowered using ramps of slope 1:20 with landing at appropriate intervals to equally achieve a clear minimum height of 2.75 m (-1.5 m). The advantage of such subways is that the walking length of a pedestrian is not increased to that extent that discourages her/him from using it. **Fig. 32** shows a typical sections of subway.
- Full subways:** Pedestrian paths are lowered to a depth where a clear height of 2.75 m minimum can be achieved using 1:20 slope ramps with appropriate landings. The car lanes encounter no level change and maintain the same level. Small shop may be included in the planning of subway which may provide a sense of safety to the pedestrian traffic during night time. This will also help maintain the subway. Even cost of construction and maintenance of subway may be recovered by allowing shops to operate in the subways. **Fig. 33** shows a typical section of a hump subway. Subway with 40 m length should be provided with forced ventilation facilities in busy areas. While planning and designing the subway, an attempt should be made to ensure natural lighting and ventilation as much as possible.
- FOB:** this is of least priority, since the walking length increases considerably.

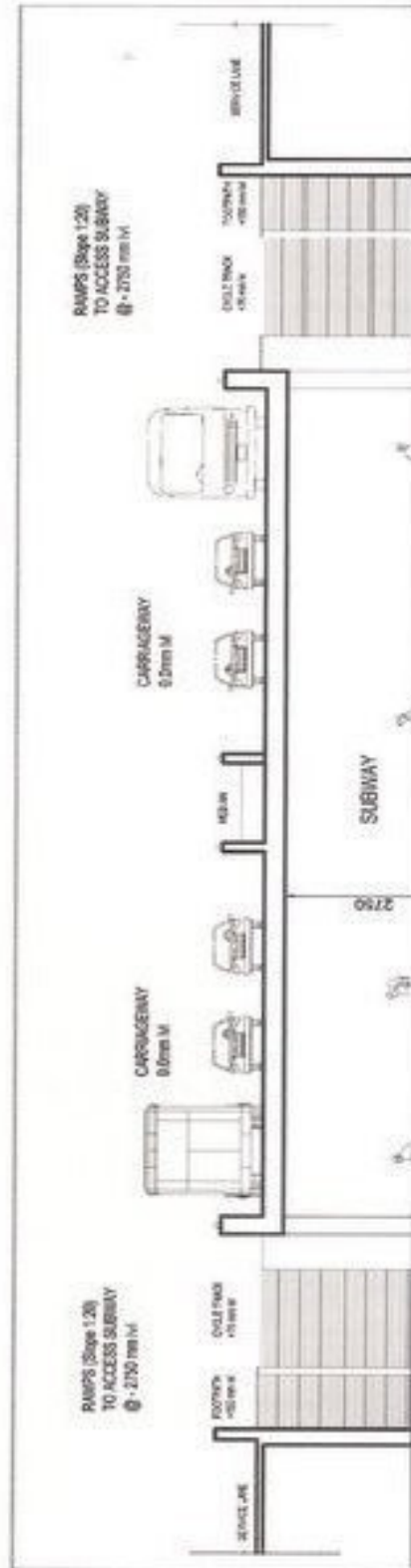
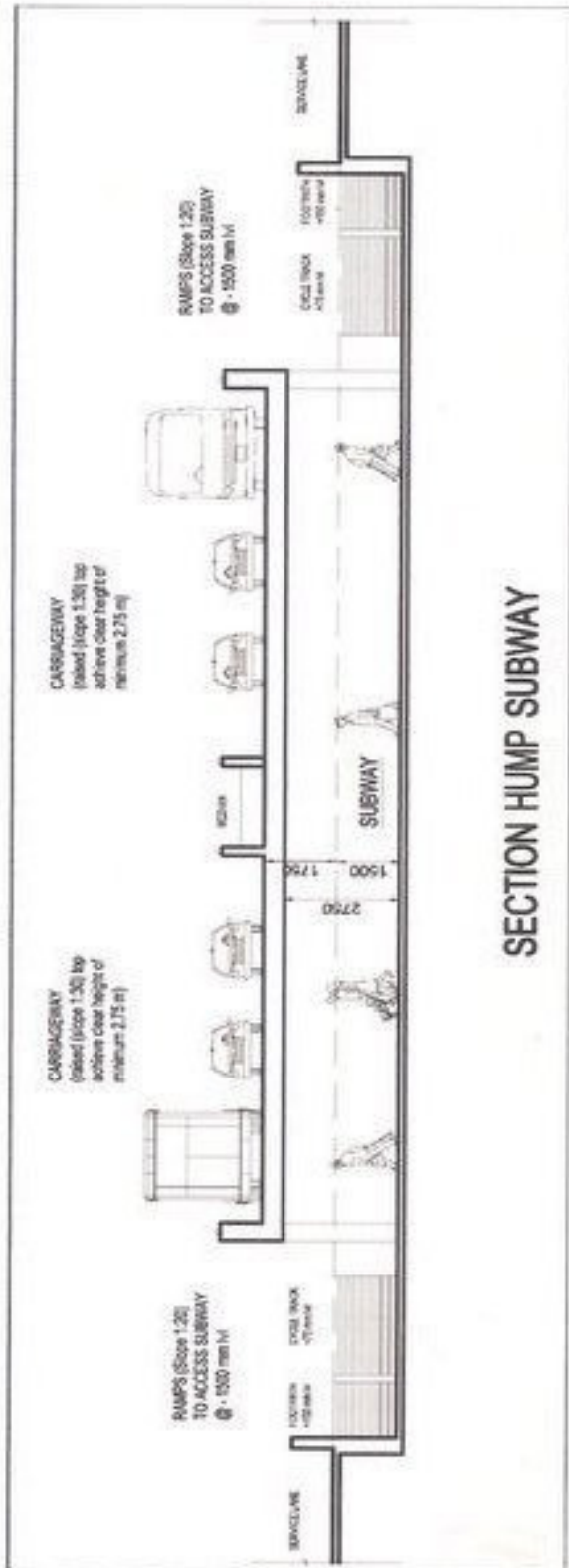
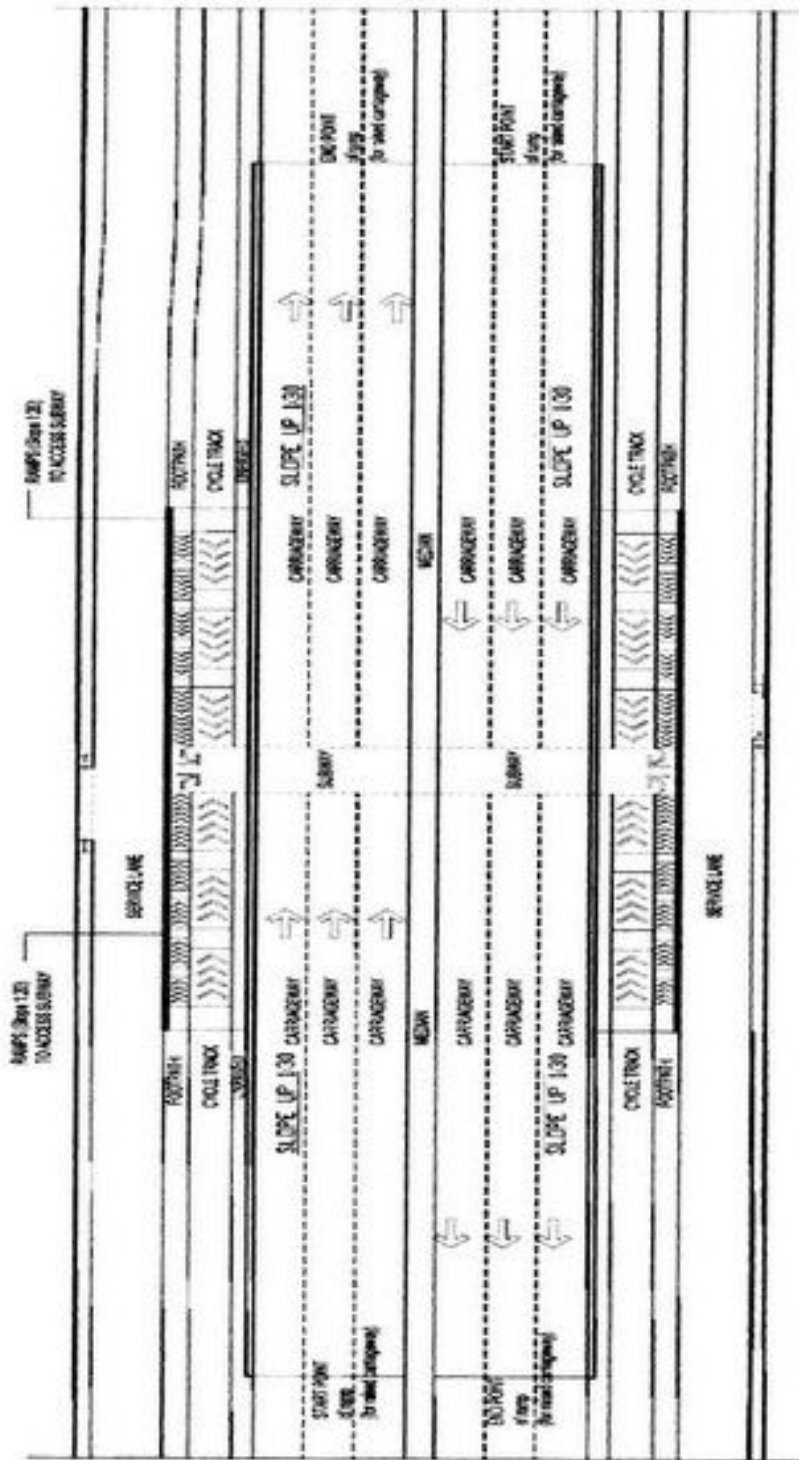

Fig. 32 Section of Full Subway



PLAN - SUBWAY

Fig. 33 Typical Section of a Hump Subway

#### 6.7.4.2.3 Subway and foot over bridges (FOB)

Escalators are generally not considered desirable as an option for inclusive mobility. Approach to subways and footbridges should comprise of ramps/elevator or inclinator and steps, except that in the subway situation. The widths should be as generous as possible.

A slope of 5 per cent (1 in 20) on footbridge ramps with appropriate resting places/landings is preferable as per section 6.8. Within the subway, a handrail set 760 mm-900 mm above the walking surface should be provided. To assist visually impaired people, tactile paving/tiles and a colour contrast should be provided 300 mm before and after i.e. at the top and bottom of the flight of steps and these areas should be well lit. Ramp/lift is mandatory and steps/escalators can be provided. Lift should be provided on both the entrances/exits and should have minimum internal dimensions of 1500 mm x 1500 mm (**Fig. 41-43**). More natural light for the subways should be provided. Greater safety can be achieved by having hawkers spaces in some subways and/or video surveillance camera. Minimum width of the FOB should be 1800 mm.

### 6.8 Ramps and Steps

Ideally, both steps and ramps should be provided. Some persons with disabilities (such as crutch users) find it easier to use steps rather than a ramp. However, in the external environment, if there is no room for both, a ramp (**Fig. 34**) should be provided. The route should not be tortuous, nor deliver persons out of the way in which they want to go.

#### 6.8.1 Ramp

A ramp should be accompanied by a flight of easygoing steps. Slope of ramp is to be a maximum of 1:12. Refer **Table 6** for ramp gradients for long lengths which will facilitate water to drain away from the ramp surface and from landings. Grill type gullies can be provided across the width of the ramp surface to ensure good drainage. Slip-resistant smooth surfaces can be used such as ribbed or brushed concrete, textured stone or macadam. Landings at every 750 mm of vertical rise should be provided and minimum width of the ramp will be 1200 mm. Handrails are to be on both sides at two levels 760 mm and 900 mm; both ends are to be rounded and grouted and to be extended to 300 mm beyond top and bottom of ramp. Surfaces (ramp + landing) should be slip resistant. Tactile warning tile 300 mm will be provided before and end of ramp to indicate change in gradient. On long ramps, one can provide passing bays, 1800 mm x 1800 mm every 20 m. Landings should be at least 1500 mm x 1500 mm. Where a door or gate opens onto a landing, the length of the landing should be at least 1300 mm clear of the door swing. Edge protection 100 mm high is required at the sides of ramps and landings to prevent persons falling through. A turning circle of 1800 mm diameter will be provided at the top and bottom of all ramps.



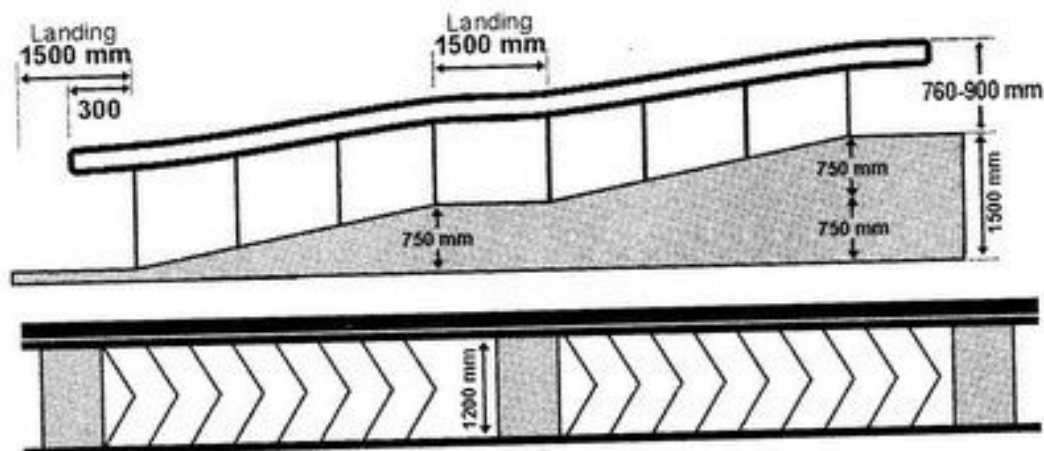

Fig. 34 Ramp Design

Table 6 Minimum Specifications for Ramps

Level difference	Minimum gradient of Ramp	Ramp width	Handrail on both sides	Comments
$\geq 150$ mm $\leq 300$ mm	1:12	1200 mm	✓	
$\geq 300$ mm $\leq 750$ mm	1:12	1500 mm	✓	Landings every 5 meters of ramp run.
$\geq 750$ mm $\leq 3000$ mm	1:15	1800 mm	✓	Landings every 9 meters of ramp run.
$\geq 3000$ mm	1:20	1800 mm	✓	Landings every 9 meters of ramp run.

### 6.8.2 Steps

Uniform risers of 150 mm and tread of 300 mm shall be adopted for the stairs. Stair edges should have bright contrasting colors. Maximum height of a flight between landings shall be 1200 mm. Landing should be 1200 mm deep, clear of any door swing. The steps should have an unobstructed width of at least 1200 mm. Top and bottom landings with a strip of tactile warning blocks (Fig. 35), is to be provided to give advanced tactile warning of a change in level. The first and last steps should provide a permanent visual contrast with the rest of the steps. Flights and landings should have a clear unobstructed width of at least 1000 mm. The rise between landings should not exceed 1200 mm. Heights of risers should be consistent throughout the flight. Tapered treads and open risers should not be used. Nosing should be avoided. There should be a suitable continuous handrail (Photo 12) on each side of flights and landings. The handrail tops should be 600–900 mm above the pitch line of the flight of steps and above the surface of the landing. Handrails should extend at least 300 mm beyond the top and bottom risers and terminate in a closed end that does not project into the path of travel and should be provided on both the sides (Photo 13). Handrails should project 50 mm from a wall to allow adequate grip/ knuckle space. The rise of each step should be no greater than 150 mm, consistent throughout the path. It is convenient for all users if the numbers of

steps in each flight are equal. The gradient should not be steeper than 1:20, and individual flights should be less than 9.0 m.

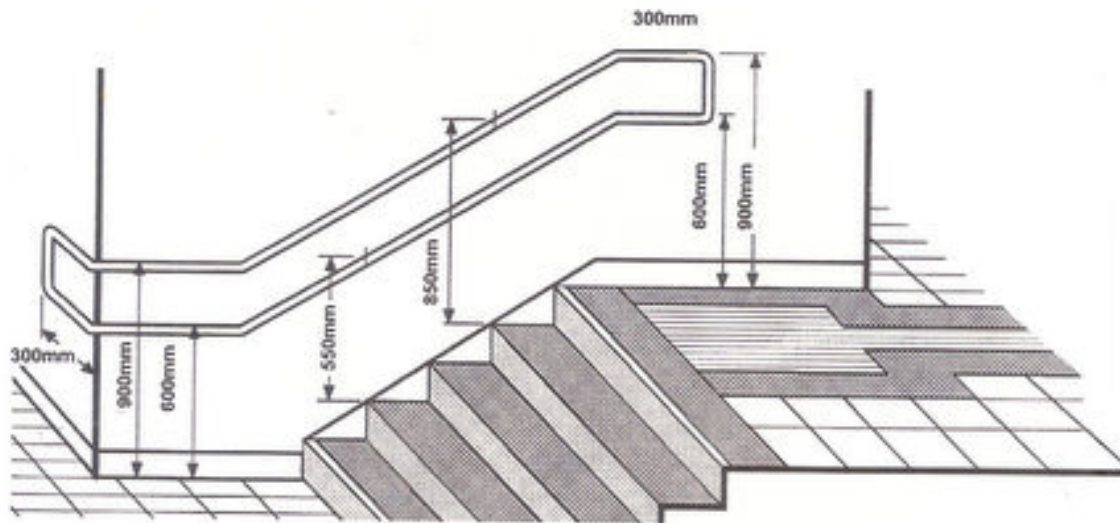

Fig. 35 Warning Strip 300 mm Before and After the Steps with Handrails



Photo 12 Continuity of Handrails



Photo 13 Handrails on Both Sides

### 6.8.3 Handrail

A continuous handrail on each side of the flights and landings should be provided. The handrails should be between 760 mm and 900 mm above the ramp and landing surfaces (Fig. 36). Handrails should extend 300 mm beyond the ramp and steps at the top and bottom, and terminate in a closed end that does not project into the path of travel. Handrail profile and projection from a wall should be suitable to allow adequate grip. Handrail should be circular in diameter of 38-40 mm with clear knuckle space of 50 mm (Fig. 37). Handrails should be supported centrally on the underside so there is no obstruction to the passage of the hand along the rail. There should also be a minimum of 600 mm clear space above the handrail. Colour/tonal contrasted handrails are essential to assist persons with low vision.

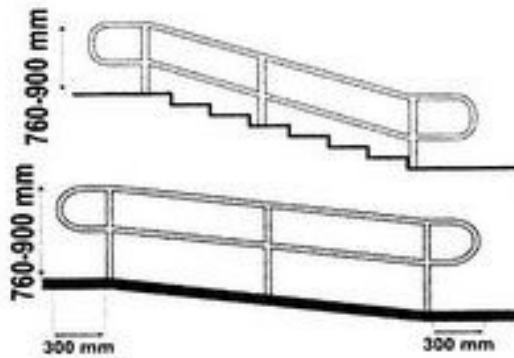

Fig. 36 Height of Handrails

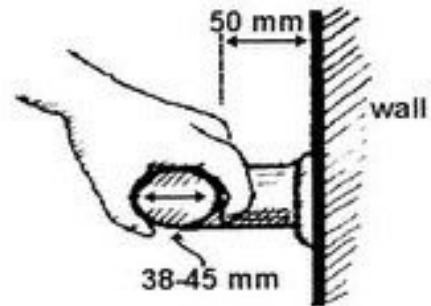

Fig. 37 Knuckle Space of Handrails

### 6.9 Elevator/Lift

A carefully designed lift makes a huge contribution to the accessibility of an subway/FOB for persons with disabilities and reduced mobility. Lift locations should be clearly signposted (Fig. 38-40) from the main pedestrian route, and recognizable through design and location. The colour and tone of the lift doors should contrast with the surrounding wall finish to assist in their location. Minimum lift car space should be 1500 mm x 1500 mm. Doors should be 900 mm wide and closing mechanism is to be adjusted to give adequate entry time. Call button and control panel will be placed at a reach of 800 mm-1000 mm with at least 400 mm from any corner or have a clear floor space of at least 900 mm x 1200 mm with no obstruction placed to prevent a wheelchair user from reaching the call button. There should be no gap or difference in level between the lift door and the floor surface at each level. If such a gap is unavoidable, then it should not be more than 10 mm. Review mirror and kick plates are to be fitted. The lift should have a voice announcement system along with a visual display to indicate the floor level. A clear landing area of minimum dimensions 1500 mm x 1500 mm (Fig. 41), in front of the lift doors should be provided. Handrail is to be placed at a height of 900mm from the floor level; and is to be fixed on both sides and at the rear of the lift (Fig.42). The landing area shall be made distinguishable by texture and colour of floor surface. It will aid location and recognition of core areas. The floor level/location should be indicated on the wall adjacent to or just above the call buttons, and opposite the lift doors wherever possible. Buttons with Braille and raised letters in sharp contrast from the background are meant to aid persons with vision impairments (Fig. 43).

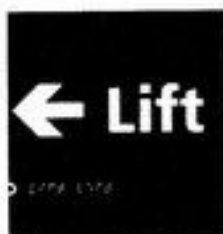

Fig. 38

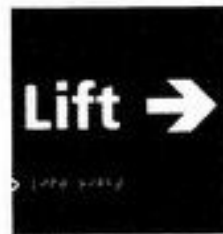

Fig. 39 Way Finding Signage for Lift Location



Fig. 40

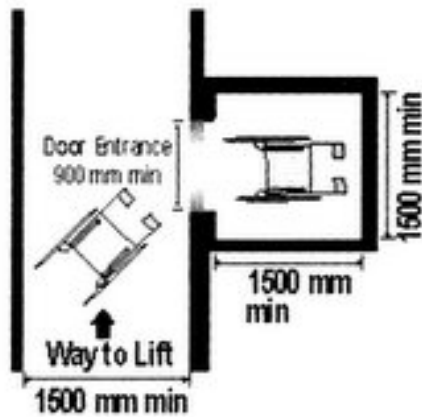

Fig. 41 Dimensions of Lift Lobby and Lift

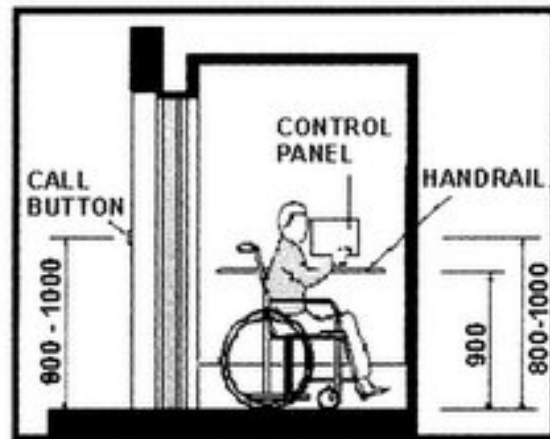

Fig. 42 Placement of Lift Accessories

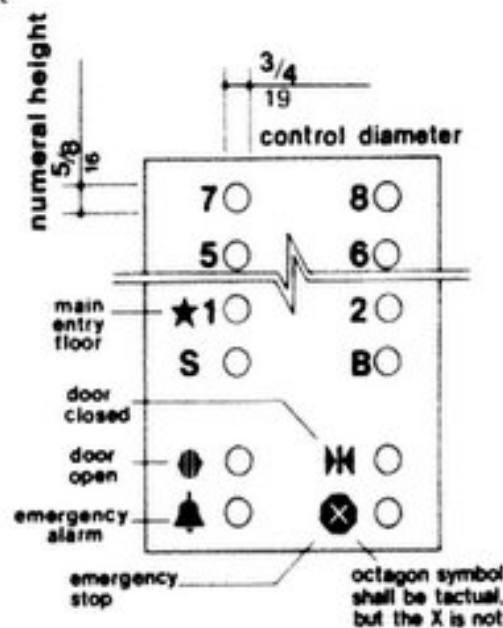

Fig. 43 Layout of Lift Control Panel

### 6.10 Multi-Functional Zone

Multifunctional Planting zones with native Street Trees and Plantation are essential on every street to provide shade and climatic comfort. Planting zones can also function as natural storm water catchments and filtration systems, aiding in ground water recharge, preventing seasonal flooding and reducing the pressure on piped storm water infrastructure.

#### Key Guidelines:

- Multi-Functional Zones (Fig. 44) on a street should be a minimum of 1.8 m wide, and may locate any or all of the following functions within them:

- Tree Planting; Planting for Storm Water Management; Auto-rickshaw Stands; Cycle-rickshaw Stands; Hawker Zones; Car Parking; Street Furniture; Bus Stops, Street lights/ pedestrian lights.
- Provision of MFZ is most critical otherwise the above uses/ components of streets would encroach upon pedestrian, cyclist or carriageway space.
- Common Utility Ducts and Duct Banks should not be located under the MFZ as there may be interference due to trees.

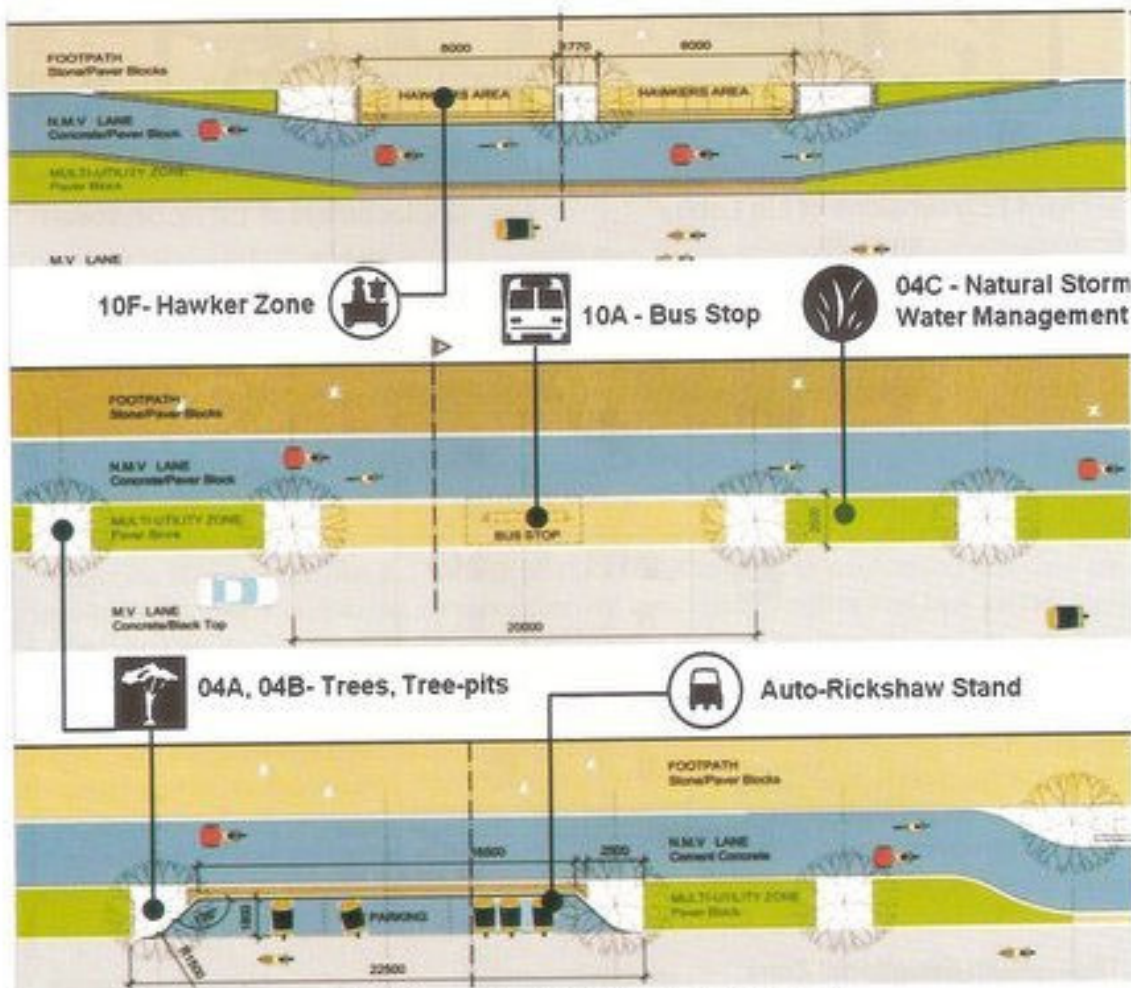

Fig. 44 Layout of Multi-Functional Zone

## 6.11 Street Furniture

### 6.11.1 General

Furniture in the external environment consists of a diversity of elements such as light post, seats, Kiosks, hawker zones, bins, information panels, traffic signs, parking meters and post boxes etc, often placed independently over time and without co-ordination. In urban environments, the complexity of the layering of these elements can result in unsafe movements for most

persons, particularly for persons with visual impairments and those using a wheelchair or pushing a pram/buggy.

All Indian cities experience street vendors operating on major roads and they are important service providers for road users especially pedestrian. They are often found as a consequence of the demand generated on the streets. Usually, they are found encroaching the footpath or the left most lane of the carriageway, which affects the users that are found to be using this facility. In such cases, the pedestrian or cyclists (riding in the left most lane in the carriageway) are pushed toward the median with the chances of mixing with fast moving traffic.

Such activities are to complement economic viability. Integration of road infrastructure will surely reflect a safer and functional design. The sheer advantage of integration of such demand as part of road infrastructure is that they cater to cyclists, pedestrian including bus commuters. Hawker spaces do not affect the space but these affect function for the mobility of the pedestrian. Their presence also ensures safety. It is therefore important to integrate the hawkers' activities as a part of the design depending on intensity of activities

#### 6.11.2 *Allocation and design of hawker space*

Hawkers should be relocated/ allocated a space. Least displacement is necessary for the adequate use of the space to be allocated. The size of the space should be equal or more to accommodate requirement of the hawkers. It should be low maintenance, attractive and easy to use.

6.11.3 Following are the requirements to outline a designed space for this vital component of road infrastructure. The determinants for the design are as follows:

- **Location:** Designated space should be such that the spillover of activities or clientele does not start encroaching the pedestrian path. However, additional spaces could be planned and designed near auto rickshaw/ short-parking term bays for vehicles that are clearly distinct from the other lanes/tracks/ infrastructure. The ideal location is to integrate the space after allocating space for the carriageway, lanes/tracks and pedestrian paths. The hawkers can then be integrated along the pedestrian path in case of arterials and along the carriageway between parking bays in a distributor street.
- **Material:** Use of material can be same as that of the pedestrian path or a mix of materials can be used to evolve a pattern in the paving. It should be attractive enough for vendors to use it. The material should ensure no hindrance in drainage.
- **Edge Treatment:** The edges could be designed using street furniture like benches and bollards.
- **Change in Elevations:** It would not be wise to segregate levels in case the area is small. Hawkens and vendors would like to be as close to their client and a change in level from the pedestrian path would not ensure a fluid movement of their clientele. A visual segregation works the best in such cases since it is also easier to demarcate territory, incase regulations are to be enforced.

- **Access:** Space should be easily accessible by all types of hawkers. Some of the hawkers use bicycles and wheeled-carts. To ensure easy access of such spaces, a mountable kerb could be designed. Another provision would be the use of ramps provided for level access for persons with disabilities. Such a design would ensure 90% usage and would minimize conflicts between users especially with cyclists and would prevent accidents.

#### 6.11.4 *Placement of street furniture*

In both rural and urban situations, proper placement of furniture out of the line of movement, is necessary so that persons do not bump into it. Good placing and coordination of furniture will result in a tidy, legible pathway or street that is easy to move along. Elements should be placed in straight lines. For instance, light posts define the main zone of objects in a street. Therefore bollards, traffic signs and post boxes can follow this line. Bulky objects such as post boxes should not be placed where they will become a visual obstruction at crossing points. The line of furniture should allow a clear circulation corridor of 1800 mm, minimum 1200 mm, wide. This dimension allows a wheelchair user and a pedestrian to pass each other without having to give way. In addition to these, provision of rain shelter facility should be provided at appropriate places so as to enable the pedestrian to protect against heavy rain. It is essential to provide wash facility at selected intervals to prevent involuntary compulsive nuisance.

#### 6.11.5 *Need for resting places/seats*

Elderly and disabled pedestrians need to rest at reasonably frequent intervals. Provision of resting places - simple sitting areas with chairs, benches or steps where one can have a break - is an important element of pedestrian spaces (**Fig. 45**). Resting spaces and shelter should also be provided where frequency is more.

- As with all street furniture, seating should be placed next to the footpath without obstructing it, and painted in contrasting colours. Seats can be as simple as wooden benches or perch-type rails to lean against.
- Seats should be 450 mm and backrest 700 mm high (**Fig. 46**).
- Tables with knee clearance of 700 mm and 600 mm deep (**Fig. 47**) should be provided with 600 mm clear width of table and wheelchair space of 1000 mm (**Fig. 48**).
- Along frequently used pedestrian ways, seating should be provided at regular intervals, typically every 50 metres.
- It is helpful to people with sight problems if these and other amenity areas adjacent to walkways and pedestrian routes are available in contrasting colors.

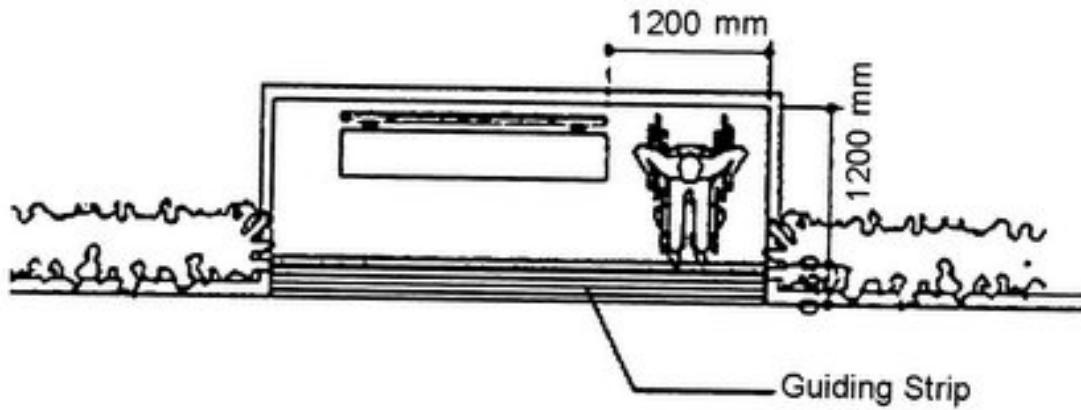

Fig. 45 Adjoining Spaces in Resting Facilities

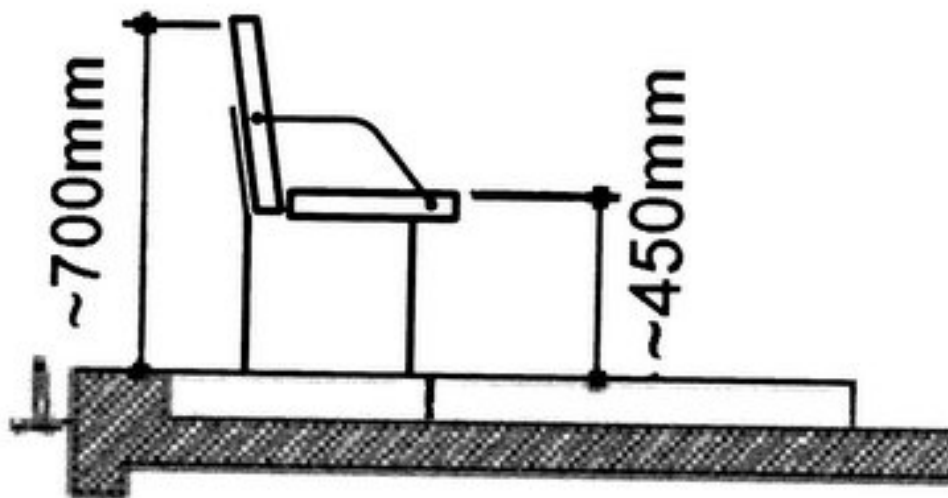

Fig. 46 Public Seats and Benches with Arm Rest

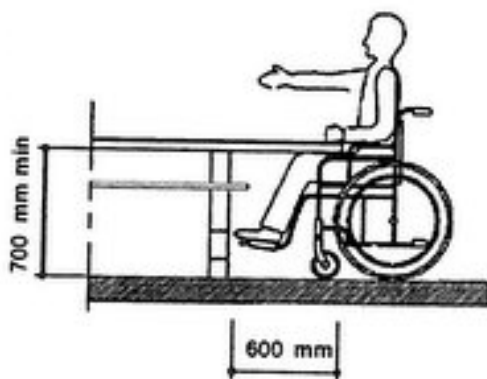

Fig. 47 Knee Clearances in Tables in Public Places

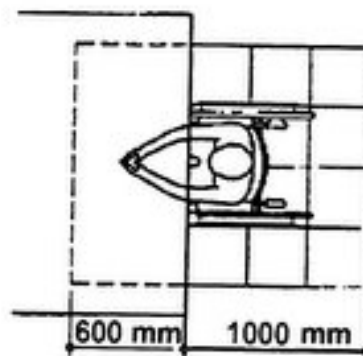

Fig. 48 Resting Facilities and Tables in Public Places



### 6.11.6 Colour and contrast

Furniture should contrast in colour and in tone with the background against which it is seen and should be highlighted by means of a 75–100 mm high feature, such as a crest or band, which contrasts in colour and tone with the furniture itself.

Furniture should be continuous to ground level. Pedestal-mounted objects should be avoided such as litter bins, telephones or letter boxes. Items attached to posts should face in the direction of travel so that they do not interfere with the line of movement. Where eye-level signs, such as maps, are supported on two vertical poles, a tapping rail located between the posts at around 250 mm above ground level prevents an unsuspecting pedestrian colliding with the sign. The rail and posts should be colour contrasted with their background.

### 6.12 Bollards

- Bollards are often used to stop vehicles from entering the footpath and to keep pedestrian away from vehicular traffic. Unless positioned carefully, they can form a barrier to wheelchair users and are a particular hazard for persons with visual impairments.
- They are essential, so as to ensure clear escape routes. Bollards with minimum 1000 mm high should be identifiable by using contrasting colours with the provision of reflective tapes.
- To stop use by bicycles/bikes, bollards at suitable locations should be provided with clear gap of 1200 mm between two bollards. (Fig. 49).

## Bollards

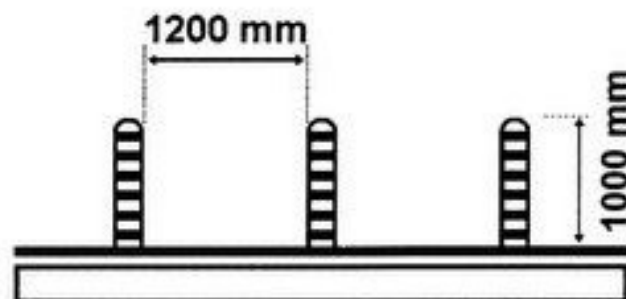

Fig. 49 Height and Gap Between Bollards

### 6.13 Lighting

Personal security is especially important to vulnerable groups such as elderly people and women (including girls and women with disabilities) more than men and good lighting is particularly necessary for pedestrian crossings, public transport facilities and for car parks. Concentrated lighting is especially required where congregation of pedestrian is expected i.e. at bus stops, near crosswalks, near street furniture. Lighting should be accentuated at all intersections and hazard-prone areas.

- Lighting shall be directed downward (**Fig. 50 & 51**) at all times (up-lighting must be prohibited).
- Lighting must be provided every 20–30 m interval, focusing light on the pedestrian and bicycle lanes and not on the car lanes.
- Pedestrian lighting should illuminate the pedestrian walkway; appropriate lighting fixtures not exceeding a height of 4m from ground grade level should be provided.
- Recessed lighting on the ground along vehicular access, ways and pedestrian walkways should be highly encouraged.
- Wall-mounted lighting, besides reducing street furniture, ensures a more even distribution of light, reducing the risk of damage due to vehicle impact and vandalism.
- All exterior lighting fixtures shall conform to the shielding requirements.
- A whiter light source, for example high-pressure sodium, is preferable in city and town centres for the aesthetic effect and for better colour definition, which benefits those with poor sight.
- White lighting at 25–40 lux for footpaths is recommended. It is recommended to maintain colour contrast from road and to ensure colour contrast of tactile tiles visible at night to persons with low vision.
- Location of lighting fixtures must consider the location of existing and proposed trees.
- Spacing of fixtures should be based on the intensity of light, height of the fixture and the clearances from tree canopies such that no light is blocked by the summer foliage.
- Higher lighting levels (80 lux) using special light poles for pedestrian crossing is recommended, while lower level light poles are preferred to avoid shadow where there are high trees.
- Under no circumstances should the lighting pole interfere with the clearance of the main pedestrian walkway of the footpath. Light pole may preferably be located within the tree-planting zone.

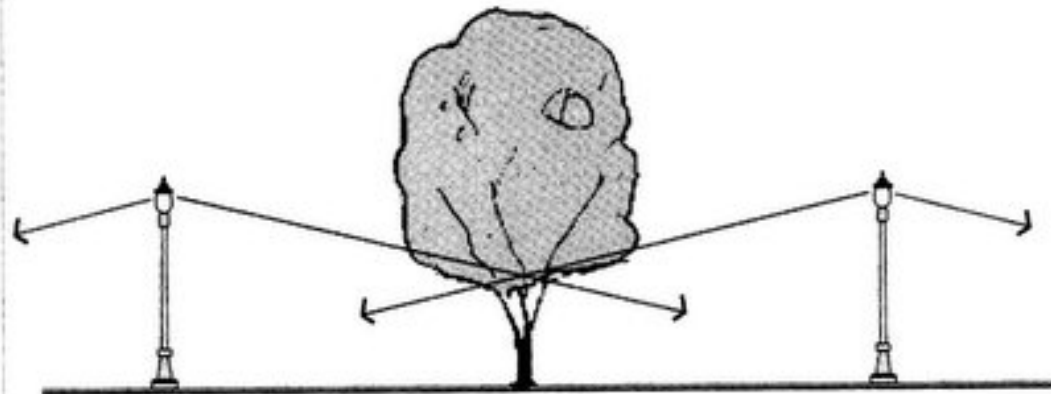

Fig. 50 Lighting Directed Downward, Poles Spaced Away from Trees

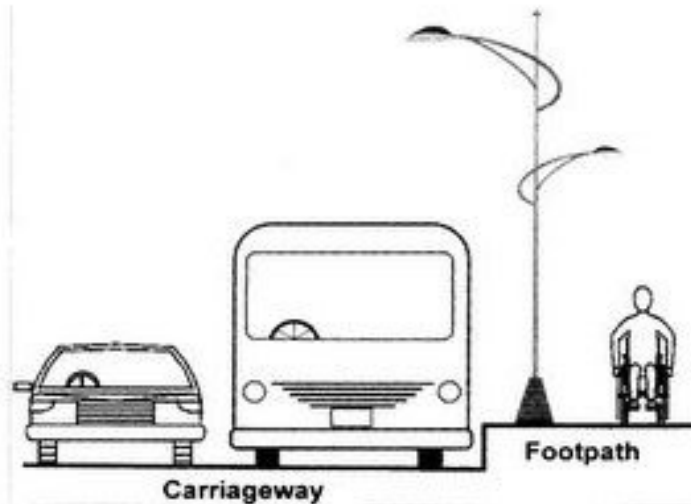

Fig. 51 Lighting on the Footpath

#### 6.14 Washrooms and Toilets

Unisex accessible public toilets (multi-use toilets) should be provided preferably at every 5 km distance for use by pedestrians.

- Accessible toilets should have the international symbol of accessibility displayed outside for wheelchair access.
- The toilet door should be an outward opening door or two way opening or a sliding type and should provide a clear opening width of at least 900 mm. It should have a horizontal pull-bar, at least 600 mm long, on the inside of the door, located so that it is 130 mm from the hinged side of the door and at a height of 1000 mm.

##### 6.14.1 WC Compartment dimensions

- The dimensions of a unisex toilet are critical in ensuring access. The compartment should be at least 2200 mm and 2000 mm (Fig. 52).
- Layout of the fixtures in the toilet should be such that a clearing maneuvering space of 1500 mm x 1500 mm in front of the WC and washbasin.

##### 6.14.2 Water closet (WC) fittings

- Top of the WC seat should be 450-480 mm above finished floor level, preferably be of wall hung or corbel type as it provides additional space at the toe level.
- An unobstructed space 900 mm wide should be provided to one side of the WC for transfer, together with a clear space 1200 mm deep in front of the WC.
- WC should be centred 500 mm away from the side wall, with the front edge of the pan. It should be 750 mm away from the back wall along with a back support. The WC should not incorporate a lid, since this can hinder transfer.

- The cistern should have a lever flush mechanism, located on the transfer side and not on the wall side and not more than 1000 mm from the floor.

#### 6.14.3 Grab bars

- It is essential that all grab rails are adequately fixed, since considerable pressure will be placed on the rail during maneuvering. Grab bars should sustain weight of 200 kgs minimum.
- A hinged type moveable grab bar should be installed adjacent to the WC on the transfer side. This rail can incorporate a toilet tissue holder. A distance of 320 mm from the centre line of the WC between heights of 200-250 mm from the top of the WC seat. It should extend 100-150 mm beyond the front of the WC.
- A fixed wall-mounted L-shape grab bar (600 mm long horizontal and 700 mm long vertical) on the wall side should be provided. It should be placed at a height of 200-250 mm above the WC seat level.

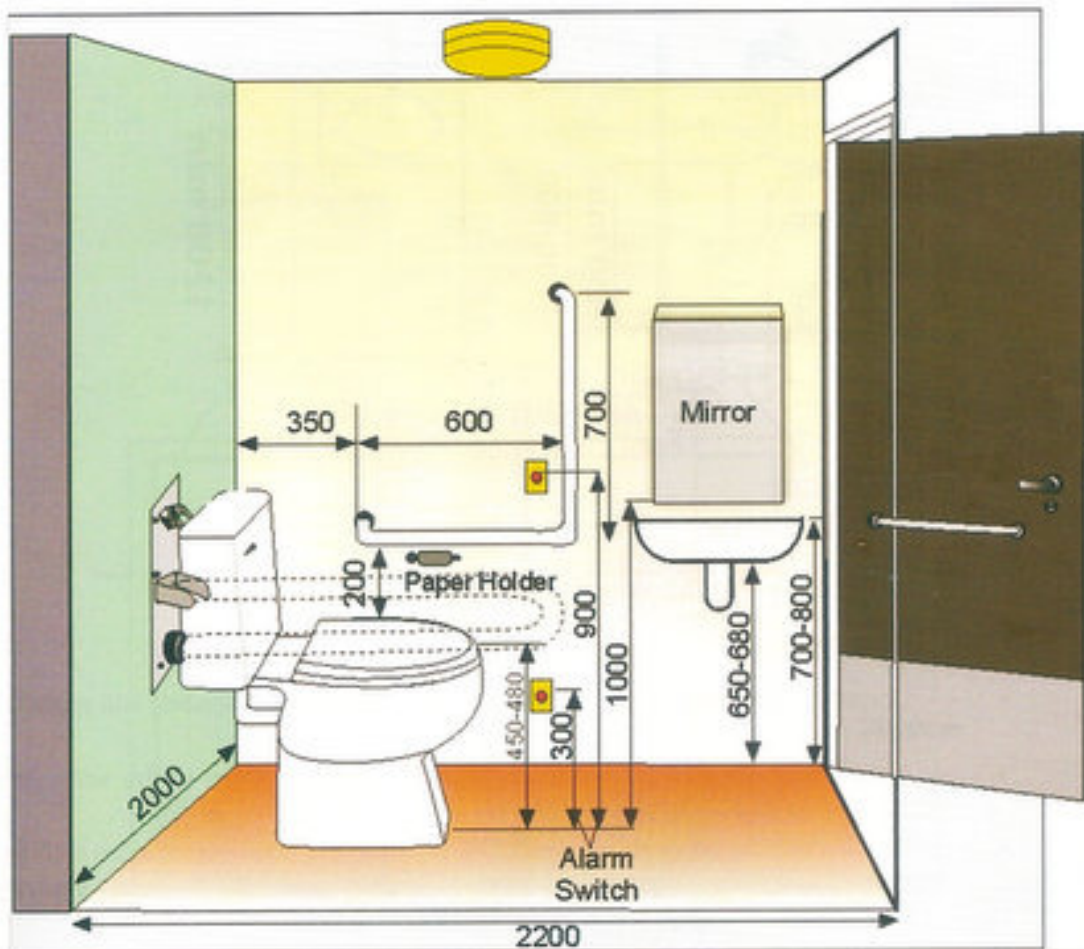

Fig. 52 Accessible Toilet

**6.14.4 Wash basins**

- Wash hand basins should be fitted on cantilevered brackets fixed to the wall.
- The basin should be fixed not higher than 750mm above finished floor level.
- It should have dimensions 520 mm and 410 mm, mounted such that the top edge is between 800- 900 mm from the floor; with a knee space of at least 760mm wide by 200mm deep. It should have a height 650-680 mm.
- The basin should not restrict access to the WC. It should be located 900mm away from the WC.
- The hand drying facilities should be located close to the wash hand basin within a distance 1000-1200 mm.
- Lever type handles for taps are recommended.

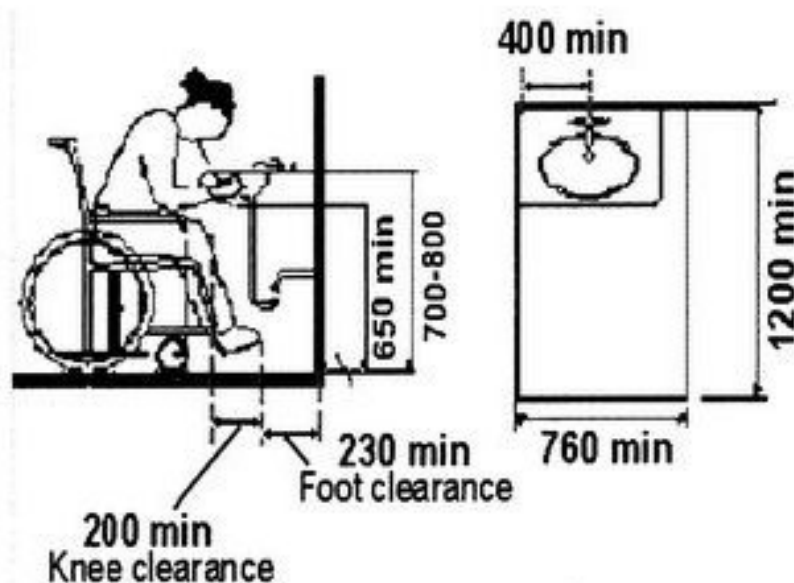

Fig. 53 Washbasin Standards

**6.14.5 Fixtures and fittings**

- Contrast between fittings and fixtures and wall or floor finishes will assist in their location.
- Towel rails, rings and handrails should be securely fixed to the walls and positioned at 800-1000 mm from the floor.
- Mirror's bottom edge should be 1000 mm from the floor and may be inclined at an angle. The mirror should be tilted at an angle of 30° for better visibility by wheelchair users.
- Hooks should be available at both lower-1200 mm and standard heights-1400 mm, projecting not more than 40 mm from the wall.

- Emergency alarms (panic buttons) must be located so that assistance can be sought both when on the WC seat i.e. at 900 mm height and lying on the floor i.e. at 300mm, from floor surface. Alarms should be located close to the side wall nearest the WC seat, 750 mm away from rear wall.

#### 6.14.6 Signage of accessible toilets

- All unisex accessible toilets should have access symbol in contrast colours (Fig. 54).



Fig. 54

- For the benefit of the persons with vision impairment, all general toilets should have male pictogram in triangle or female pictogram in circle, marked on plates with raised alphabets and put on wall next to door and on the door as well (Fig. 55).
- A distinct audio sound (beeper/clapper) may be installed above the entrance door for identification of the toilets.

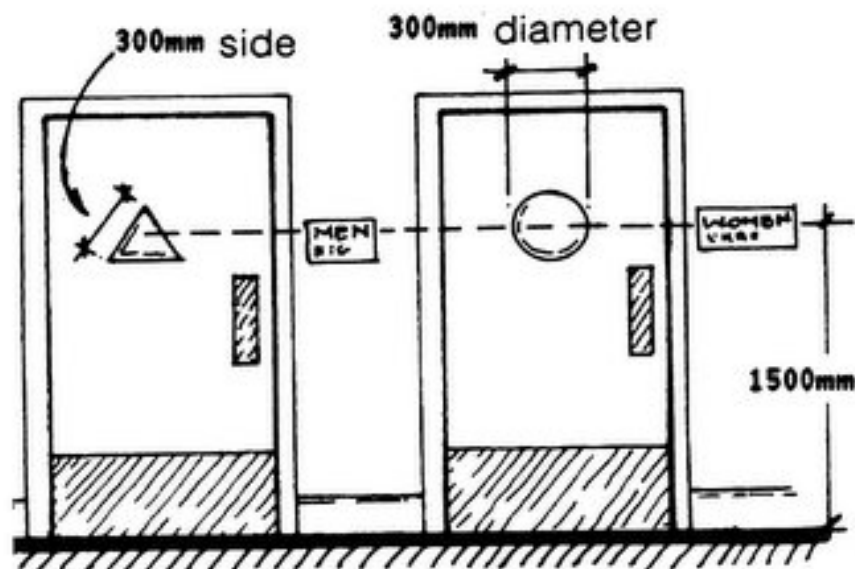

Fig. 55 Placement of Signage

**6.14.7 Accessible urinal**

At least one of the urinals should have grab bars to support ambulant persons with disabilities (for example, crutch users).

- A stall-type urinal is recommended.
- Urinals shall be stall-type or wall-hung, with an elongated rim at a maximum of 430 mm above the finish floor.
- Urinal shields (that do not extend beyond the front edge of the urinal rim) may be provided with 735 mm clearance between them.
- Grab bars to be installed on each side, and in the front, of the urinal (**Fig. 56**).
- The front bar is to provide chest support; the sidebars are for the user to hold on to while standing.

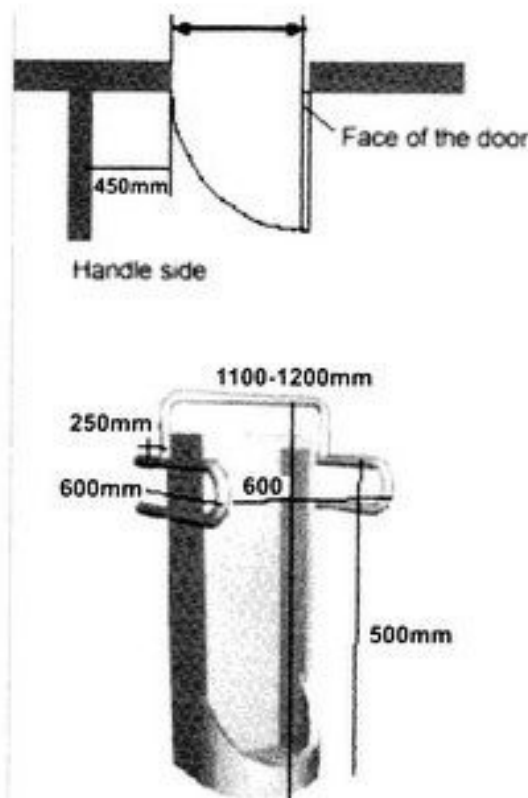

Fig. 56 Urinal with Chest Support Grab Bar

**6.15 School Zone Improvements**

Traffic safety around schools is an important concern to parents, school officials, and communities. Improvements should start at the planning level; when new elementary schools are sited, they should be located inside neighborhoods to minimize the need for young children to cross busy arterial streets. These schools should not face busy arterial streets. School

officials need to review attendance boundaries and walking attendance boundaries so that young children do not have to face unnecessary challenges on their way to and from school.

Schools should plan for "Safe Routes to School" walking and bicycle plans to serve all residences within the walking attendance boundary and work with local agencies to identify and correct traffic problem areas while developing these plans. These "Safe Route to School" walking and bicycling plans help to identify where traffic control (signs, traffic signals, crosswalks, adult guards, etc.) should be placed around the school and along school routes. Marked crosswalks can help guide children to the best routes to school with these plans..

A number of roadway improvements can be used to enhance the safety and mobility of children walking to or from school. Footpaths need to be kept clear of obstructions and should be promptly repaired when damaged. Wider footpaths should be used closer to schools where larger groups of students are walking.

The greatest hazards to all pedestrian occur when crossing streets; young children are even more vulnerable, as they have trouble judging traffic and finding an acceptable gap to cross. Traffic Marshals are generally required to be deputed to ensure safe crossing of school children. Some of the most effective safety treatments are low-cost and easy to implement measures such as larger standing areas and stand-back lines to keep students further back from busy streets while waiting to cross. Students drop off area should be clearly marked.

Police enforcement in school zones are required in situations where drivers are speeding or not yielding to children in crosswalks. Radar speed boards and other innovative enforcement programs, such as photo speed or red-light cameras may also be employed at some crossings.

One of the biggest safety problems around schools is often created by parents or caretakers dropping off and picking up children. There are two immediate solutions:

- This needs to be a clearly marked area where parents are allowed to drop off and pick up (Photo 14 & 15) their children, and
- drop-off/pick-up regulations must be provided to parents prior to the first day of school. Drop-off areas must be situated away from where children on foot cross streets or access the school and should be designed to provide the appropriate amount of on-site vehicle storage or queuing along the on-street drop-off zone. Parent drop-off zones must be segregated from bus drop-off zones.



Photo 14 Signage for Student Drop off/Pick up Zone





Photo 15 Marking of Student Drop off Area

Following steps are suggested for ensuring safety at schools:

- An effort should be made to ensure high degree of road safety by taking confidence, cooperations and all possible help from the local traffic police, schools offices, parents and students and neighboring areas.
- School attendance and walking attendance boundaries should be reviewed and may need to be adjusted and planned to provide safest walking and bicycling conditions for children.
- "Safe Route to School" walking maps should be prepared to serve all homes within the walking attendance boundaries of all elementary schools and middle schools.
- There are a number of engineering treatments and traffic control techniques that can be applied to improve safety and walkability at schools and school crossings. Each school will be required to utilize its own set of engineering treatments.
- Local officials should take initiative to review school area footpaths, crosswalks, and other traffic control devices annually to make sure that they are in good condition before the start of the next school year.
- School officials need to ensure feedback to local officials and police to help identify problems areas or maintenance needs.

## 6.16 Pedestrian Facilities-Parking

### 6.16.1 Provision and siting

Adequate parking places shall be provided to discourage indiscriminate parking, as this can obstruct building access. Where parking is provided, priority should be given to the persons with impaired mobility, so that they can park their cars as convenient to entrances as possible.

### 6.16.2 Designated car parking spaces-accessible parking

Following are the important issues for accessible parking:

- Designated car parking spaces may be arranged perpendicular or parallel to the kerb. Dropped kerbs will facilitate access to the footpath for persons using wheelchairs (Photo 16).

- If arranged perpendicular to the kerb, a minimum 900mm clear space beside the designated bay so as to facilitate wheelchair transfer from car to footpath (Fig. 57) should be provided. Cars can be driven forward or reversed into the bay, so that the transfer space is at the right side.
- Two accessible parking lots with overall minimum dimension 3600 mm x 5000 mm, should be provided (Fig. 58).
- It should have the international signage painted on the ground and also on a signpost/board put near it.
- There needs to be directional signs guiding people to the accessible parking.
- Wheel stoppers should be provided to avoid vehicles to occupy space on the pedestrian footpath.
- The transfer side should be taken care of in case spaces are arranged parallel to the kerb. A disabled driver or passenger getting out on the kerb side may transfer directly onto the wheelchair located on the footpath.
- This can be very difficult if the kerb is high, as it necessitates lifting the wheelchair out of the car up onto the footpath, and then lifting oneself up onto the chair from the car seat. This problem does not present itself if parking is perpendicular to the kerb, as transfer will always be onto road level. This may be more convenient, assuming the provision of appropriate kerb ramp provide access to the footpath.
- Where parallel parking is the only option, some persons prefer to transfer on the road side to avoid the kerb, despite the obvious hazards. If they do so, a clear space of 1200 mm must be available at the ends of the car to allow them to gain access to the footpath.
- In some situations, where footpath width is restricted, it may be appropriate to ramp the footpath down to road level for the full length of the parking spaces in question.
- In car parks of 25 cars or less, the roadway may be used for transfer purposes, provided this area is clearly visible to approaching traffic and the roadway is not a through road.



Photo 16 Accessible Parking with Aisle Space and Kerb Ramp

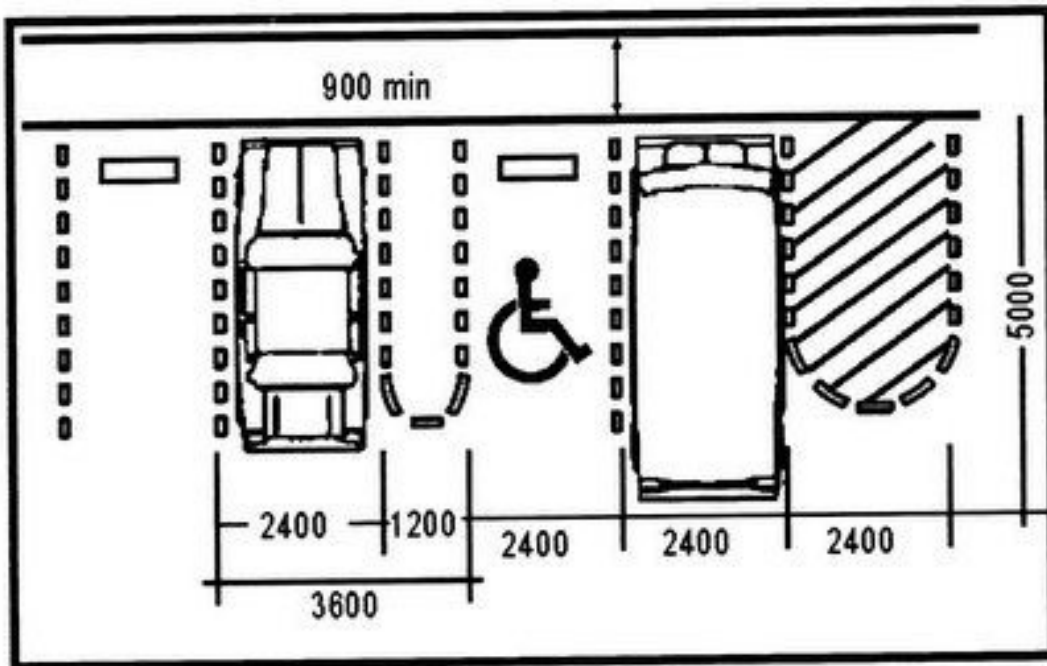

Fig. 57 Plan of Accessible Parking

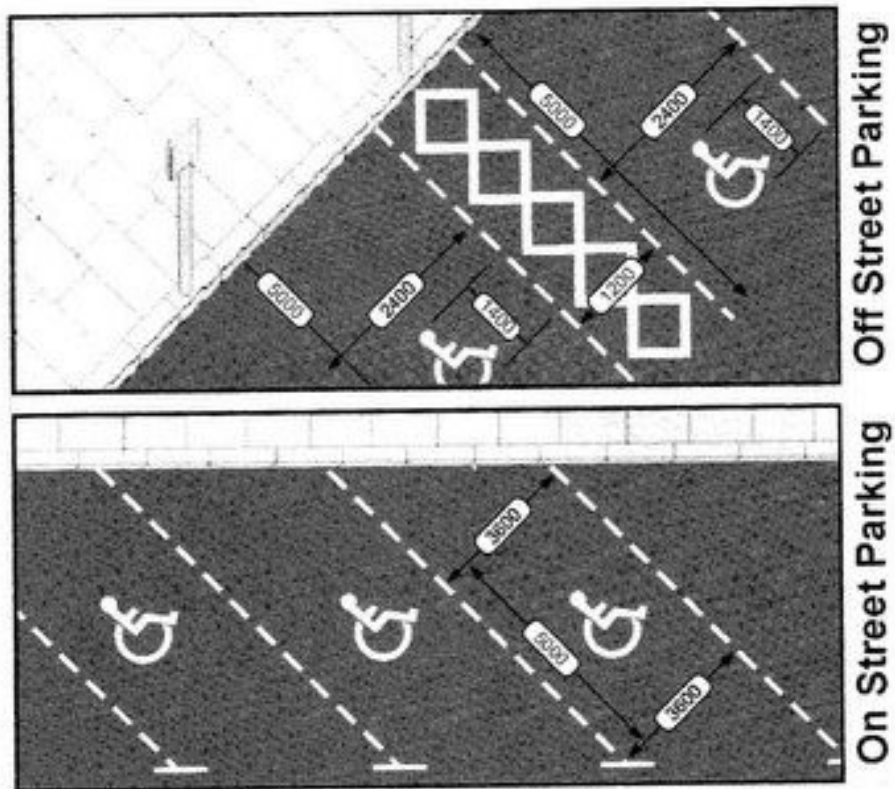

Fig. 58 Accessible Parking

### 6.16.3 Drop-off/boarding points

Provide a drop-off/boarding point near entrances marked by wheelchair (access) symbol painted on the floor and put on a pole at height of 2 m (**Photo 17**). Passengers with impaired mobility often move slowly and therefore are vulnerable in bad weather. Persons with visual impairments also benefit from having direct access to the building entrance. Provide protection from the weather wherever possible. A canopy height of 2500 mm facilitates most passenger vehicles.

**Drop-off points** should be level, with a firm surface. Avoid siting manholes, drainage gullies etc in areas where persons get out of cars, in particular at kerb ramps. Such items can impede walking sticks, crutches and wheelchairs and can become hazardous in cold weather. Drop-off points should not obstruct circulation areas. Avoid transfer directly onto footpaths or, if this is not possible, ensure that the footpath is at least 2000 mm wide at the drop-off, point.



Photo 17

### 6.17 Pedestrian Facilities at Transit Areas

Pedestrian are extremely exposed and vulnerable even within the transit areas due the presence of vehicular traffic in most of the Indian cities. Transit areas include right from the bus stop, bus station, bus terminal to railway and airport terminal. Even at the interchange where both a central bus station and a metro station co-exist, the dispersal of pedestrian traffic is of paramount importance. Walkways have a very important role to play in linking the interchange points of different transport systems – bus, trains, metro to allow easy and comfortable dispersal. This distance should be the shortest and the most direct route which should be walkable and safe. From this perspective, the integration of the bus station with the metro stations through a walkway that allows people easy access with minimal conflict ensures pedestrian friendly environment.

Walking is an ideal mode for a trip length of 500 m to 1 km. To promote walk trips as well as to provide adequate pedestrian facilities the preferences and perceptions of the pedestrian need to be understood in a rational manner. Pedestrian facilities should be planned in an integrated manner so as to ensure a continuous pedestrian flow. It should be useful therefore

to look at the pedestrian needs for an area for different types of transit areas. The following components have to be considered for provision of pedestrian facilities at transit areas.

<b>FACILITIES FOR PEDESTRIAN IN TRANSIT AREAS (Photo 18-21)</b>	
<b>A.</b>	<b>WALKABLE AREA WITHIN THE TRANSIT AREA</b>
	The permissible walking distance in transit area is 400m & the sufficient area for pedestrian to be aware of other pedestrian in transit area is required to be 1.9-3.3 sq.m./person.
	The maximum flow of pedestrian for public transit occurs when transit stops are within a 10 minute walking distance from source.
	Direct pedestrian path makes it easier for people to walk.
<b>B.</b>	<b>PEDESTRIAN FACILITIES IN TRANSIT AREAS- WALKWAYS</b>
	Pedestrian walkways should be planned with minimum width of 2 m with accessible grade changes.
	Pedestrian should not have to walk more than 200 m to ramp or elevators to change floor level to access transit.
<b>C.</b>	<b>FOOTPATH/FOOTPATHS</b>
	1.8-2 m footpath/footpaths for light pedestrian traffic.
	5 m footpaths for heavy pedestrian traffic.
	To allow walking at near normal speeds, the footpaths must provide continuity without any obstacles.
<b>D.</b>	<b>CROSSWALKS</b>
	The cross walks should be provided at every 30 m on the pedestrian streets.
	At the zebra crossing, width of zebra crossing should be within the range of 2 m–4 m.
	The minimum island size should be 15 sq.m.
	The radii at the corner of the streets varies from 0.7 m to 1.7 m and with curbside parking it can vary from 1.7 m to 3.5 m.
	In case of raised median, being used as pedestrian refuge, such portion could be suitable depressed with curb height not exceeding 150 mm.
<b>E.</b>	<b>RAMPS</b>
	Ramps must have maximum slope of 1: 20. A level walking space should be provided at the top of the ramp.
	The ramps and landings are required where the slope exceeds 5 per cent.
	For ramps maximum permissible slope is 8.33% with minimum width of 1m.
	The hand rails should be installed along the side of the ramp; more than 0.15m or the length should be greater than 2 m.
	The diameter of the hand rail should not be more than 35 mm for proper gripping.
<b>F.</b>	<b>OTHER PEDESTRIAN FACILITIES IN TRANSIT AREAS</b>
	Signage can add several pedestrian friendly qualities to the streets.
	Use of special paving to break up an expanse or to link pedestrian path with the transit stop restricting pedestrian and vehicular conflicts.
	Street trees should be placed less than 30 m apart.



Photo 18 Pedestrian Facilities at Transit Area



Photo 19 Different Material for Pedestrian Facility



Photo 20 Signage at Transit Area



Photo 21 Pedestrian Movement Inside Transit Area

## 6.18 Road Safety Audit and Pedestrian Facility Audit

**6.18.1** An effective in identifying potential safety issues and recommending countermeasures is the Road Safety Audit (RSA). RSA is a formal examination of the safety performance of an existing or planned road or intersection by an independent audit team. RSAs are different from traditional safety reviews in a number of important ways. First, an RSA is conducted by a multidisciplinary team, including safety and design experts independent of the project. RSAs always result in generation of a formal report.

**6.18.2** Traditional safety reviews focus primarily on vehicle traffic while RSAs broaden the scope to consider all potential road users and account for their capabilities and limitations. A top priority for RSAs is to consider all roadway users, minimizing the unintended consequences, especially for pedestrian.

**6.18.3** The benefits of an RSA include the design and reconstruction of facilities that reduce the number and severity of crashes, and the reduction of costs by identifying safety issues and correcting them before projects are implemented. RSAs also promote awareness of safe design practices, the value of integrating multimodal safety concerns, and consideration of human factors in all facets of design.

**6.18.4** The following issues need to be addressed while conducting the pedestrian safety audit. It is also necessary to work out a comprehensive check lists to conduct the audit in consultation with Road Safety Auditor.

- Needs of Pedestrian: Do pedestrian facilities address the needs of all pedestrian including those with disabilities?
- Connectivity and Convenience of Pedestrian Facilities: Are safe, continuous, and convenient paths provided along pedestrian routes throughout the study area?
- Traffic: Are design, posted, and operating traffic speeds compatible with pedestrian safety?
- Behavior: Do pedestrian or motorists regularly misuse or ignore pedestrian facilities?
- Construction: Have the effects of construction on all pedestrian been addressed adequately?
- School Presence: Is the safety of children in school zones adequately considered?

### REFERENCES

- Access Board (2004), Americans with Disabilities Act and Architectural Barriers Act Accessibility Guidelines United States Architectural and Transportation Barriers Compliance Board (U. S. Access Board), Washington DC ([www.access-board.gov/ada-aba/final.pdf](http://www.access-board.gov/ada-aba/final.pdf))
- Access Board (2006), ADA Standards for Transportation Facilities, United States Architectural and Transportation Barriers Compliance Board (U. S. Access Board), Washington DC. ([www.access-board.gov/ada-aba/ada-standards-dot.cfm](http://www.access-board.gov/ada-aba/ada-standards-dot.cfm))
- Access for All (2008), Second Edition, Training Manual to promote Barrier Free Environment, Guidelines for TOT for promotion of Universal Design, RCI & Samarthyam
- Agarwal Anjlee (2009), "Accessibility and Comparative analysis of Building Standards and Regulations (Building Bye-Laws) in various states of India", Ministry of Urban Development, Government of India. (Available at [http://www.urbanindia.nic.in/programme/ud/Research%20Study\\_Building%20Regulations\\_Access%20Standards.pdf](http://www.urbanindia.nic.in/programme/ud/Research%20Study_Building%20Regulations_Access%20Standards.pdf))
- Agarwal Anjlee (2009), "Research Study on Road Safety Aspects of Persons with Disabilities", National Trust, Government of India
- Agarwal Anjlee (2011), Action Oriented & Advocacy Research Study specific to India on the Anthropometrics of Persons with Disabilities- Users of Mobility & other Aids, DFID-VSO (underway)
- American Association of State Highway and Transportation Officials, Pedestrian and Bicycle Safety
- CERTU (2000), Une Voire pour tous CERTU, Lyon





- Das, Vikas ,” Crossing Behaviour of Pedestrian in Mixed traffic Conditions” , unpublished PhD Thesis submitted at the Department of Civil Engineering, IIT Roorkee, India
- Department for Transport and the Regions (2005). Guidance on the use of tactile paving surfaces. Mobility and Inclusion Unit, Department for Transport, London ([www.dft.gov.uk/pdf/transportforyou/access/peti/guidanceontheuseoftactilepav6167](http://www.dft.gov.uk/pdf/transportforyou/access/peti/guidanceontheuseoftactilepav6167))
- Designing Footpath and Trails for Access: Review of Existing Guidelines and Best Practices, Design Guide FHWA, Washington, DC, Sep 2001
- DFID / TRL (2004), Enhancing the mobility of disabled people: Guidelines for practitioners, Overseas Road Note 21, Department for International Development and TRL Limited, Crowthorne, Berkshire, UK
- Dunbar G, C A Holland and E A Mayor (2004), Older Pedestrian: A Critical Review of the Literature Road Safety Research Report No. 37, Department for Transport, London. ([www.dft.gov.uk/pgr/roadsafety/research/rsrr/theme1/olderpedestrianacriticalrev.pdf](http://www.dft.gov.uk/pgr/roadsafety/research/rsrr/theme1/olderpedestrianacriticalrev.pdf))
- ECMT (1986), Transport for disabled people - International comparisons European Conference of Ministers of Transport, OECD Publications Service, Paris.
- ECMT (2006), Improving transport Accessibility for All European Conference of Ministers of Transport, OECD Publications Service, Paris.
- Hitchcock A and C G B Mitchell (1984), Man and his walking behaviour. Part 2a. Walking as a means of transport. Transport Reviews, 1984, Vol. 4, No. 2, pp177-187.
- IHT (2005), Traffic calming techniques, Institution of Highways and Transportation, London.
- Inclusive Mobility (1991): A Guide to Best Practice on Access to Pedestrian and Reducing Mobility Handicaps in the Pedestrian Environment', The Institution of Highways and Transportation
- IRC:67-2001 "Code of Practice for Road Signs" ( First Revision)
- K.S. Rakesh (2008), "Pedestrian Environment- A qualitative perspective", Architecture Time Space and People
- Kirschbaum J B et al (2001), Designing Footpath and Trails for Access Part II: Best Practices Design Guide FHWA Publication FHWA-EP-01-027, Federal Highway Administration, U. S. Department of Transport, Washington DC. ([www.fhwa.dot.gov/environment/footpath2/pdf.htm](http://www.fhwa.dot.gov/environment/footpath2/pdf.htm))
- Martin J, H Meltzer and D Elliot (1988), The prevalence of disability among adults OPCS surveys of disability in Great Britain, Report 1, Office of Population Censuses and Surveys, HMSO, London.
- Mitchell C G B (2004), Standards and guidelines for accessibility International Conference on Mobility and Transport for Elderly and Disabled People, Hamamatsu, Japan, 2004.

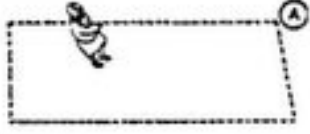
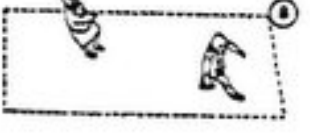

- Mitchell C G B (2007a), Old World Ways Public Roads, Vol. 70, No.5, March/April 2007, Federal Highways Administration, Department of Transportation, Washington DC. ([www.tfhrc.gov/pubrds/07mar/index.htm](http://www.tfhrc.gov/pubrds/07mar/index.htm))
- Mitchell C G B (2007b), Safe mobility for older and disabled pedestrian; International Conference on Mobility and Transport for Elderly and Disabled People, Montreal, 2007. ([www.tc.gc.ca/pol/EN/transed2007/pages/1145.htm](http://www.tc.gc.ca/pol/EN/transed2007/pages/1145.htm))
- ODPM (2004), Access to and use of buildings; The Building Regulations 2000, Part M, Office of the Deputy Prime Minister, The Stationary Office, London. ([www.planningportal.gov.uk/uploads/br/BR\\_PDF\\_ADM\\_2004.pdf](http://www.planningportal.gov.uk/uploads/br/BR_PDF_ADM_2004.pdf))
- OECD (2001), Ageing and Transport - Mobility Needs and Safety Issues; Organization for Economic Cooperation and Development (OECD), Paris.
- Oxley P R (2002), Inclusive Mobility: A Guide to Best Practice Mobility and Inclusion Unit, Department for Transport, London. (<http://www.dft.gov.uk/transportforyou/access/peti/inclusivemobility>)
- Parida, P., Najamuddin, Parida, Manoranjan (2007) "Planning, Design & Operation of Footpath Facilities in Delhi", Highway Research Bulletin, Indian Roads Congress, Delhi, Oct., No.77m pp.81-95.
- Parida, Purnima (2006) "Planning, Design and Operation of Pedestrian Facilities in Delhi", unpublished Ph.D. Thesis submitted to Department of Architecture & Planning, Indian Institute of Technology Roorkee, Roorkee.
- Rickert, T (2006), Bus Rapid Transit Accessibility Guidelines World Bank, Washington DC
- Streetscape Design Guidelines for City of Lancaster Pennsylvania
- Streetscape Guidance for the Transport for London Road Network (2004), TfL
- The DPTAC Recommended Specification, published by the Disabled Persons Transport Advisory Committee, (1988)
- Transport Infrastructure' (2002), ODPM
- UTTIPEC Street Design Guidelines, DDA, New Delhi
- [www.dft.gov.uk](http://www.dft.gov.uk)
- [www.globalride-sf.org](http://www.globalride-sf.org)
- [www.icat-ciat.org](http://www.icat-ciat.org)
- [www.iitd.ac.in](http://www.iitd.ac.in)
- [www.transport-links.org/transport\\_links/filearea/documentstore/307\\_ORN%2021.pdf](http://www.transport-links.org/transport_links/filearea/documentstore/307_ORN%2021.pdf)
- [www.unescap.org](http://www.unescap.org)

Annexure-I  
(Refer Clause 6.1.5.1)

Table 1.1: Illustration of Quantitative Level of Service

<p><b>LOS A</b>  <b>Pedestrian Space &gt; 4.9 m<sup>2</sup>/p. Flow Rate ≤ 12 p/min/m</b>                  At a walkway LOS A, pedestrian move in desired paths without altering their movements in response to other pedestrian. Walking speeds are freely selected, and conflicts between pedestrian are unlikely.</p>	
<p><b>LOS B</b>  <b>Pedestrian Space &gt; 3.3-4.9 m<sup>2</sup>/p. Flow Rate ≤ 12-15 p/min/m</b>                  At LOS B, there is sufficient area for pedestrian to select walking speeds freely, to bypass other pedestrian, and to avoid crossing conflicts. At this level, pedestrian begin to be aware of other pedestrian, and to respond to their presence when selecting a walking path.</p>	
<p><b>LOS C</b>  <b>Pedestrian Space &gt; 1.9-3.3 m<sup>2</sup>/p. Flow Rate ≤ 15-21 p/min/m</b>                  At LOS C, space is sufficient for normal walking speeds, and for bypassing other pedestrian in primarily unidirectional streams. Reverse-direction or crossing movements can cause minor conflicts, and speeds and flow rate are somewhat lower.</p>	
<p><b>LOS D</b>  <b>Pedestrian Space &gt; 1.3-1.9 m<sup>2</sup>/p. Flow Rate ≤ 21-27 p/min/m</b>                  At LOS D, freedom to select individual walking speed and to bypass other pedestrian is restricted. Crossing or reverse-flow movements face a high probability of conflict, requiring frequent changes in speed and position. The LOS provides reasonably fluid flow, but friction and interaction between pedestrian is likely.</p>	
<p><b>LOS E</b>  <b>Pedestrian Space &gt; 0.6-1.3 m<sup>2</sup>/p. Flow Rate ≤ 27-45 p/min/m</b>                  At LOS E, virtually all pedestrian restrict their normal walking speed, frequently adjusting their gait. At the lower range, forward movement is possible only by shuffling. Speed is not sufficient for passing slower pedestrian. Cross- or reverse-flow movements are possible only with extreme difficulties. Design volumes approach the limit of walkway capacity, with stoppages and interruption to flow.</p>	
<p><b>LOS F</b>  <b>Pedestrian Space ≤ 0.6 m<sup>2</sup>/p. Flow Rate varies</b>                  At LOS F, all walking speeds are severely restricted, and forward progress is made only by shuffling. There is frequent, unavoidable contact with other pedestrian. Cross- and reverse-flow movements are virtually impossible. Flow is sporadic and unstable. Space is more characteristic of queued pedestrian than of moving pedestrian streams.</p>	

Speed- Density, Speed- Flow and Flow Space models are used for development of Level of Service. Fig. I.1 and Fig. I.2 show the relationship between the above parameters.

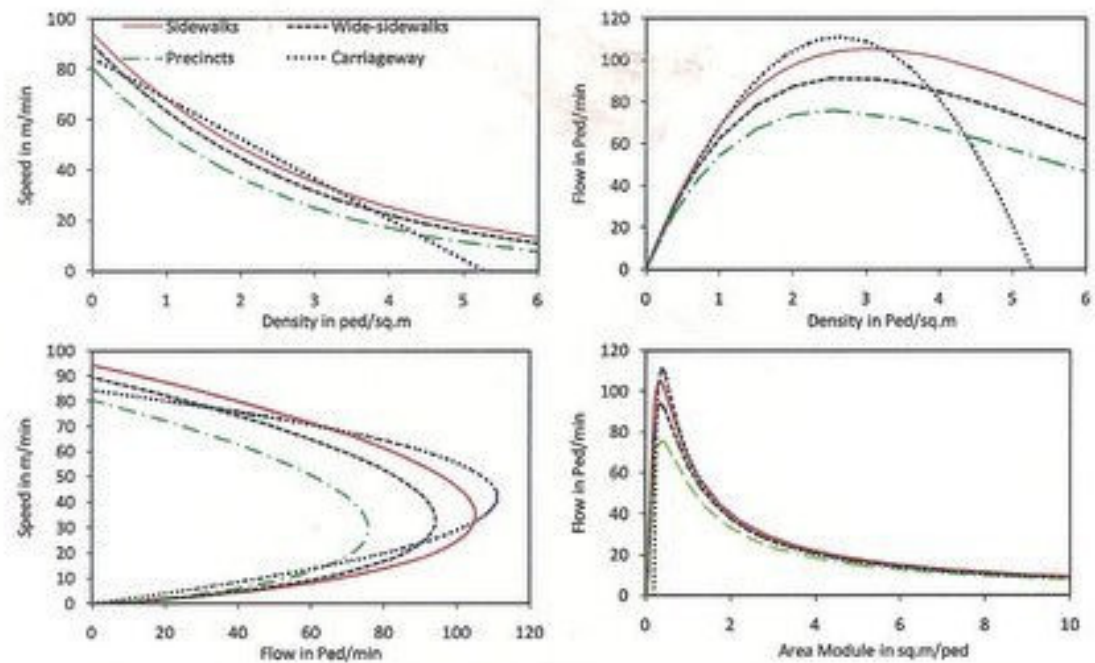

Fig. I.1: Speed –Flow-Density Relationships for Pedestrian Movements

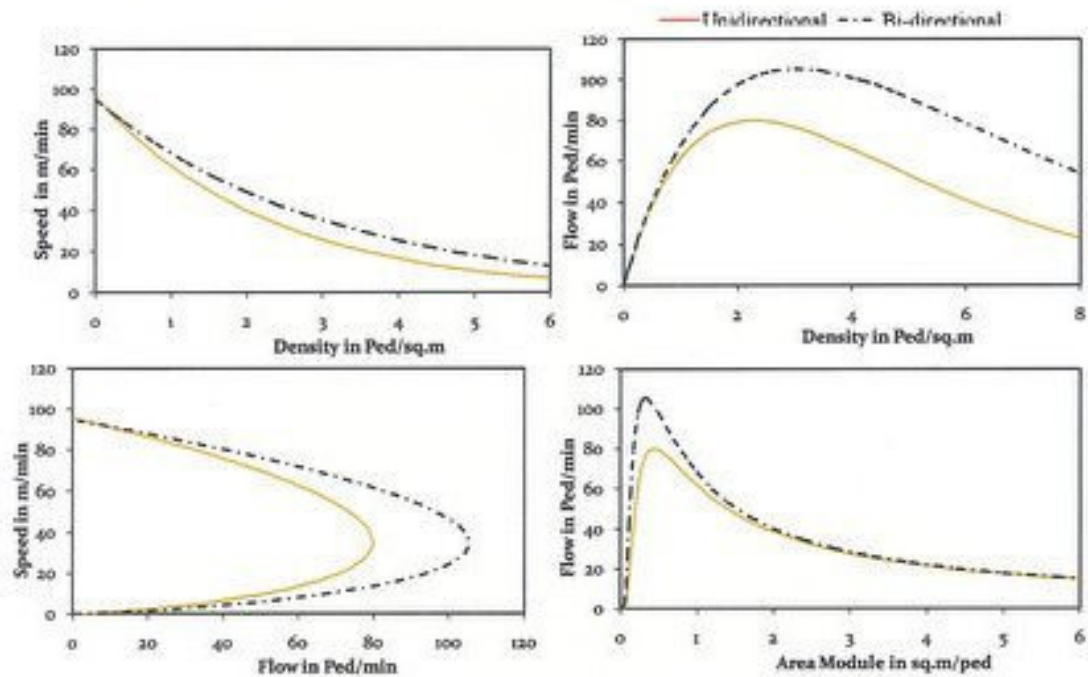

Fig. I.2: Speed-Flow-Density Relationships for Directional Movements

Pedestrian' delay in crossing the road is used as basic criteria in defining the Level of Service at pedestrian crossings as presented in the **Table 2**.

**Table 1.2 Pedestrian Level of Service at Road Crossing**

Level of Service	Waiting Time in seconds
A	$\leq 3$
B	$>3$ and $13 \leq$
C	$>13$ and $38 \leq$
D	$>38$ and $64 \leq$
E	$>64$ and $90 \leq$
F	$\geq 90$

In **Table 1.3** and **Fig. 1.3**, the actual lengths or widths of people and equipment; the clearance lengths and clear outdoor passage widths needed for those people and equipment are given.

**Table 1.3 Dimension of people and equipments**

Minimum passage width – stick/walker user	750 mm
Minimum passage width - double crutch user	920 mm
Minimum passage width - adult and child	1100 mm
Minimum passage width - adult plus helper	1200 mm
Minimum passage width - adult plus guide dog	1100 mm
Minimum passage width – wheelchair user plus ambulant person	1500 mm
Minimum passage width – single stroller	610 mm
Minimum passage width– person with vision impairment using white cane	1500 mm
Length of pram plus pusher	900 mm
Length of 95 <sup>th</sup> percentile wheelchair	1250 mm
Length of wheelchair plus pusher	1750 mm
Length of adult plus guide dog	1500 mm
Length of powered scooter	1270 mm
Length of electric footpath vehicle (average)	1400 mm
Eye level of wheelchair user	1265 mm
Seated height of wheelchair user	1300-1400 mm
Turning circle - manual wheelchair (also small electric)	1575 mm
Turning circle - outdoor electric wheelchair	2420 mm
Turning circle - electric footpath vehicle	4350 mm



**Fig. 1.3 Lengths or Widths of People and Equipment**

**Annexure-II**  
**(Refer Clause 6.1.6)**

**Recommended Materials for Pedestrian Facilities**

	<b>Areas</b>	<b>Do's</b>	<b>Don'ts</b>
(1)	Footpath	Non-skid / matt finish tiles, interlocking paving tiles, sandblasted Stone, unpolished Stone, checkered tiles, Pavement Quality Concrete	Polished Stone finishes
(2)	Kerb ramps	Anti skid / matt finish tiles; Flared sides with tactile paving, exposed Cement Concrete	Polished Stone finishes
(3)	Tactile paving	Vitrified unglazed pavers in bright colour contrast to the flooring surface (preferably canary yellow)	Stainless steel or metal pavers in dull /slippery finish
(4)	Signage	Bright colour contrast big font signage on non-glare surface-acrylic, retro reflective sheets as per IRC:67-2010	
(5)	Bus Stops flooring	Anti skid / matt finish tiles with vitrified unglazed tactile pavers in bright colour contrast to the flooring surface	Glazed vitrified tiles, Granite, polished Kota stone
(6)	Streetlights	White color, mercury lights-full cutoff fixtures	Yellow lights
(7)	Handrails	Stainless steel 304/316, OD-40-45mm, scotch-brite or matt finish	
(8)	Light signals	Audio signals with time display	Normal light signals
(9)	Table top	Any load bearing anti-skid pavers, tiles	Cobble stone
(10)	Table top slopes (on road side)	Cobble stone maybe provided	Polished granite or any other Slippery Surface
(11)	Median refuges	Any load bearing anti-skid pavers, tiles	Cobble stone
(12)	Cycle tracks	Preferred Pavement Quality Cement Concrete	CC Paver Tiles and Polished Finishes